

Part No. P0937240 02

Business Communications Manager 2.5

Telephone Features Programming Guide

NORTEL
NETWORKS™

Copyright © 2001 Nortel Networks

All rights reserved.

The information in this document is subject to change without notice. The statements, configurations, technical data, and recommendations in this document are believed to be accurate and reliable, but are presented without express or implied warranty. Users must take full responsibility for their applications of any products specified in this document. The information in this document is proprietary to Nortel Networks NA Inc.

Trademarks

NORTEL NETWORKS is a trademark of Nortel Networks.

Microsoft, MS, MS-DOS, Windows, and Windows NT are registered trademarks of Microsoft Corporation.

All other trademarks and registered trademarks are the property of their respective owners.

Contents

Preface	15
Before you begin	15
Emergency 911 Dialing	15
Text conventions	15
Acronyms	16
Related publications	17
Chapter 1	
Introduction	19
Unified Manager	19
Telephone types	19
Telephone installation	20
Name a telephone or a line	23
Extension numbers	23
Line assignment	24
Prime line	24
Private line	24
Target line	24
Overflow call routing	24
Telephone buttons	25
One-line and two-line displays	26
Buttons under the display	26
Memory buttons	27
Program buttons	27
Chapter 2	
Answer calls	29
Ring types	29
Distinctive Line Ring	29
Call Ringing	29
Call Answering	30
Line buttons	30
What line indicators mean	30
Information about a call on the display	30
Call Information for a specific call	31
View Call Information before or after answering	31
View Call Information for a call on hold	31
Make Call Display information appear automatically at a telephone	32
Change which call information appears first	32

Priority Call	32
Answer calls at a prime telephone	32
Central answering position (CAP) module	33
Customize your CAP module	34
Monitor telephones with the CAP module	34
Release button	35
Pick up a call ringing at another telephone	35
Directed Pickup	35
Group Pickup	35
Change a telephone's pickup group	36
Trunk Answer	36
Answer buttons	36
Listen to a call as a group	37
Cancel Group Listening	38
Chapter 3	
Make a call	39
Line pools	41
Use a line pool to make a call	41
Program a line pool feature code	42
Line buttons	42
Select how you dial your calls	42
Standard dial	42
Automatic dial	42
Pre-dial	43
Receive a busy signal on an internal call	43
Priority Call	43
Program a telephone to make priority calls	43
Make a priority call	43
Ring Again	44
Turn on Ring Again	44
Cancel Ring Again	45
Message	45
Create a Conference Call	45
Disconnect one party	45
Separate holding of two calls	46
Put a conference on hold	46
Split a conference	47
Leave a conference call	47

Chapter 4	
Time-saving features	49
Autodial	49
Select a line for Autodial	49
Use intercom as the line for Autodial	50
Last Number Redial	51
Prevent Last Number Redial	51
Speed Dial	51
System Speed Dial codes	52
Personal Speed Dial	52
Saved Number Redial	53
Save a number	53
Dial a saved number	53
Prevent Saved Number Redial	53
 Chapter 5	
Handling calls	55
Use Hold	55
Retrieve a held call	55
Hold automatically	55
Listen on hold	55
Hold a call exclusively	56
Call Queuing	56
Transfer calls	56
Transfer external calls	57
Cancel a transfer	57
Camp-on	58
Call Park	59
Park a call	60
Retrieve a parked call	60
Callback	61
 Chapter 6	
Forward your calls	63
Call Forward	63
Cancel Call Forward	63
Override Call Forward	64
Change the automatic Call Forward settings	64
Change Call Forward no answer	64
Change the delay before a call is forwarded	64
Call Forward on busy	64
DND on Busy	64

Call Forward and voice mail	65
Line Redirection	65
Allow a telephone to redirect calls	66
How Line Redirection is different from Call Forward	66
Turn on Line Redirection	66
Cancel Line Redirection	67
Turn the redirect ring for a telephone on or off	67
Chapter 7	
Communicating in the office	69
Page	69
Make a page announcement	69
Page Shortcuts	69
Activate and deactivate the Page feature	70
Create page zones	70
Using Page with external equipment	71
Messages	71
Send a message	71
Cancel a message you have sent	72
Review your messages	72
Reply to a message	72
Reply to a message using an analog telephone connected to an ASM	73
Remove items from your message list	73
Remove items from your message list using an analog telephone connected to an ASM	73
View messages you have sent	74
Voice Call	75
Make a Voice Call	75
Mute Voice Call tones	75
Answer a Voice Call using Handsfree Answerback	75
Voice Call Deny	76
Cancel Voice Call Deny	76
Chapter 8	
Track your incoming calls	77
Call Log	77
Call Log options	77
Log a call manually	78
Delete old log items	78
View your Call Log	78
View a Call Log item	78
Erase log items	79

Make a call using Call Log	79
Create a password to your Call Log	79
Change your Call Log password	80
Delete an assigned password	80
Program a telephone to log calls automatically	80
Chapter 9	
Customize your telephone	83
Adjust the contrast on the display	83
Change the language on the display	83
Change the type of ring	84
Adjust the Ring volume	84
Button Inquiry	84
Programming feature codes	85
Erase a feature button	85
Default button assignments	86
Rules of default button assignment	86
T7316 Button mapping	87
T7316 and T7208 telephone button defaults	88
M7324 Button mapping	88
M7324(N) telephone button defaults	89
T7100 telephone button defaults	90
Move line buttons	90
Hide the message or calls indication	91
Restore the messages and calls indication	91
Chapter 10	
Hunt Groups	93
Members of the group	94
Distribution mode	94
Chapter 11	
Telephone features	95
Moving telephones	95
Hunt Groups	95
Prevent calls from ringing at your telephone	95
Use Do Not Disturb	96
Cancel Do Not Disturb	96
Stop calls	96
Refuse to answer a call	96
Turn Privacy on or off for a call	96
Create a conference call by releasing privacy	97

Make a call private	97
Handsfree and Mute	97
Answer calls without lifting the handset	97
Make calls without lifting the handset	97
Mute Handsfree	98
Change a normal call to handsfree	98
Change a handsfree call to a normal call	98
Handsfree	98
Change Handsfree for a telephone	98
Handsfree Answerback	99
Hearing aid compatibility	99
Call Duration Timer	99
Accidental disconnect	99
Disconnect supervision	99
Time	99
Background Music	100
Cancel Background Music	100
Chapter 12	
System features	101
ISDN	101
Network name display	101
Name and number blocking	101
Use alternate or scheduled services	102
Restriction service	102
Ringing service	102
Routing service	102
Turning services on and off	102
Turn services on and off using feature codes	103
View active services from a two-line display telephone	103
View active services from a one-line display telephone	104
User passwords	105
Registration password	105
Log password	105
Special telephones	105
Direct dial	105
Change direct dial telephone assignments	106
Hotline	106
Hotline bypass	106
Make a telephone a hotline telephone	106
Control telephone	107
Set lock	107

Change Set Lock programming for a telephone	107
Auxiliary ringer	107
Turn the auxiliary ringer on or off	107
Host System dialing signals	108
Link	108
Prevent a telephone from using Link	108
Pause	108
Long Tones	108
Run/Stop	109
Wait for Dial Tone	109
Pulse or tone dialing	109
Pulse dialing for a call	110
Access your system from an external location	110
Direct Inward System Access (DISA)	110
Class of Service (COS)	110
Class of Service (COS) passwords	111
Change your Class of Service	111
Maintain security	111
Remote access over the public network	111
Tones	112
Voice mail	112
Service provider features	113
Call Forward	113
Cancel Call Forward	113
Call the number where your calls are forwarded	113
Automatic Call Back	113
Automatic Recall	114
Chapter 13	
Hospitality Services	115
Types of telephone set	115
Common set	115
Room set	115
Hospitality Services (HS) admin set	115
Alarm time (AL) feature	116
Program the Alarm time feature	116
Change or cancel an Alarm time	116
Cancel an alarm	117
Turn off an Alarm	117
Hospitality Services admin alarm feature	117
Room occupancy	118
Programming the state of a room set	118

Room condition	118
Room condition from a room set	119
Room condition with a Hospitality service admin set	119
Hospitality passwords	120
Desk admin password	120
Room condition password	120
Chapter 14	
Portable telephone and handset features	121
Portable telephones	121
Portable telephone features	122
Directed Call Pickup	123
Group Pickup	123
Wireless Portable Language Selection	123
Wireless Call Forward No Answer enhancement	123
Chapter 15	
Troubleshooting	125
Alarm codes	125
Report and record alarm codes	125
Test the telephone	125
Test the telephone display	125
Test the telephone buttons	126
Test the speaker in the telephone handset	126
Test the telephone headset	126
Test the telephone speaker	126
Test the power supply to a telephone	127
Appendix A	
Feature Codes	129
Features sorted by activation code	133
Appendix B	
Common display prompts and error messages	137
Index	141

Figures

Figure 1	T7100, T7208, T7316, M7324 and M7324N telephones	20
Figure 2	Installing a T7316 telephone (North America)	21
Figure 3	Mounting a T7316 telephone with a stand on the wall	22
Figure 4	Mounting a T7316 telephone without a stand on the wall	23
Figure 5	Display buttons	26
Figure 6	CAP module with M7324 and M7324N telephones	34
Figure 7	Button assignment on the T7316 telephone	87
Figure 8	Button assignment on the M7324 telephone	89

Tables

Table 1	Telephone buttons	25
Table 2	Telephone button functions	25
Table 3	Substitutes for buttons on a one-line display telephone	26
Table 4	Language options	83
Table 5	T7316 button assignment template	88
Table 6	T7208 button assignment template	88
Table 7	M7324(N) button assignment template	89
Table 8	Tones and what they mean	112
Table 9	Features available to a portable telephones in the system	122
Table 10	Features sorted by feature name	129
Table 11	Features sorted by activation code	133

Preface

This guide provides information about how to program a Business Communications Manager telephone. This information includes items such as programming personal speed dials, transferring a call, and using special features. Some of the features included in the Business Communications Manager telephone system are:

- conference calls
- group listening
- group pickup
- directed pickup
- call tracking

This guide is aimed at the day-to-day operators of the Business Communications Manager telephone system.

Before you begin

Plan the programming changes you want to make before you begin. Record the changes so that you have the information at hand. For example, before you program system speed dial numbers, create a record so that you have all the numbers and codes available.

Programming applies to both North America and International telephones in your Business Communications Manager system.

Emergency 911 Dialing

Emergency 911 Dialing is the capability to access a public emergency response system.

State and local requirements for support of Emergency 911 Dialing service by Customer Premises Equipment vary. Ask your local telecommunications service provider about compliance with applicable laws and regulations.

Emergency 911 Dialing may not apply to International systems.

Text conventions

This guide uses the following text conventions:

- | | |
|--------------------|---|
| angle brackets < > | Indicate the generic title on the telephone display.
Example: When querying a feature button.
<Feature name> appears in angle brackets. |
| Bold | Indicates a programming level within the telephone menu.
Example: Terminal & Sets programming level. |

<code>ClearDisplay font</code>	Indicates what appears on the telephone display. Example: <u>CALL</u> .
<i>italic text</i>	Indicates new terms and book titles. Example: <i>Business Communications Manager Telephone Feature Card</i> .
Forward slash /	Separates names where two actions are assigned to one button. Example: Run/Stop.

Acronyms

This guide uses the following acronyms:

AL	Alarm
ASM	Analog Station Module
ATA	Analog Terminal Adapter
BLF	Busy Lamp Field
BRI	Basic Rate Interface
CAP	Central Answering Position
CFB	Call Forward on Busy
CFAC	Call Forward All Calls
CFNA	Call Forward No Answer
CLID	Calling Line Identification
COS	Class of Service
DID	Direct Inward Dial
DISA	Direct Inward System Access
DN	Directory Number (Extension Number)
DND	Do Not Disturb
DLR	Distinctive Line Ring
DRP	Distinctive Ring Pattern
DRT	Delayed Ring Transfer
ERC	Express Routing code
HS	Hospitality Services
IP	Internet Protocol
ISDN	Integrated Services Digital Network
ISO	International Organization for Standardization
PBX	Private Branch Exchange
PRI	Primary Rate Interface

RC	Room Condition
RJXX	Registered Jack XX (Where XX is used to denote numbers, for example: 45 or 5.)
RO	Room Occupancy
SLR	Selective Line Redirection
URL	Uniform Resource Locator

Related publications

For more information about using Business Communications Manager 2.5, refer to the following publications:

- *Business Communications Manager Installation and Maintenance Guide*
- *Business Communications Manager Programming Operations Guide.*
This document provides more information about using Unified Manager.
- *Business Communications Manager DECT Installation and Maintenance Guide*

Chapter 1

Introduction

Your Business Communications Manager telephone system has many features that you can customize to keep up with changes in your workplace.

Unified Manager

Unified Manager is the tool used to program settings for the system telephony features, and settings for each telephone and external lines. Multiple levels of programming are accessible through Unified Manager. You access the Business Communications Manager Unified Manager from your web browser. For more information about navigation and making selections using Unified Manager, see the *Business Communications Manager Programming Operations Guide*.

Telephone types

Figure 1 shows the three different Business Series Terminals, as well as the M7324 and M7324N telephones. See [“T7100, T7208, T7316, M7324 and M7324N telephones”](#) on page 20.

Figure 1 T7100, T7208, T7316, M7324 and M7324N telephones

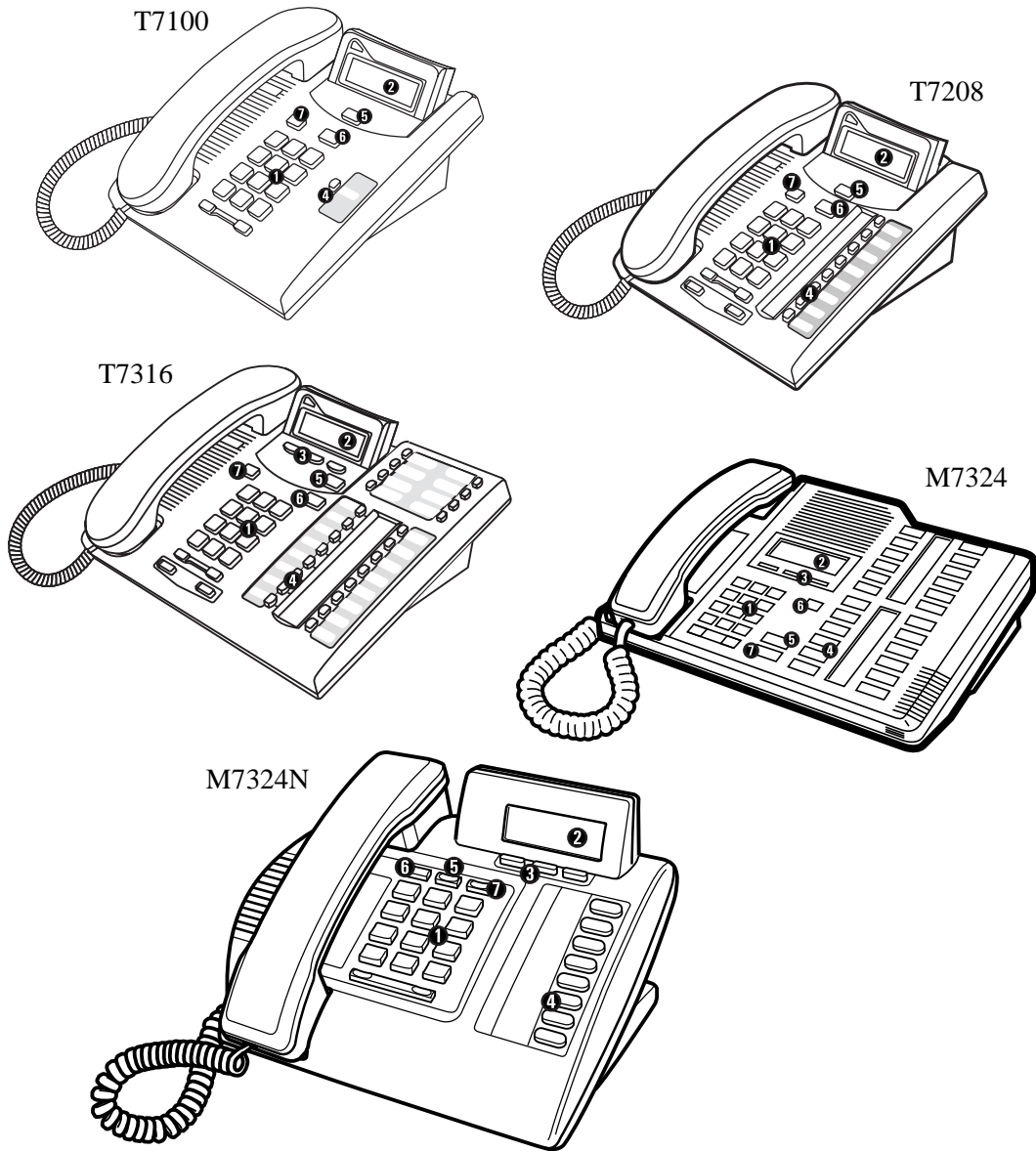

Telephone installation

If you are connecting a Business Communications Manager telephone for the first time, refer to the following illustrations and steps.

- 1** Disconnect the line cord from the wall socket before trying to carry out any work on the telephone.
- 2** To remove any of the cords, press the release latch on the plug and carefully pull the plug from the socket.

- 3 Connect the handset cord to the jack labelled with the telephone icon and route the cord as shown.
- 4 If you are using a headset, route the cord along the channel in the base and connect the cord to the telephone jack that is labelled with the headset icon.
- 5 Route the line cord through the support and connect the cord to the telephone jack that is labelled with the jack icon.
- 6 Attach the support using either pair of slots; to raise the back of the telephone to its highest position, use these slots.
- 7 When the above work is complete, plug the line cord back into its wall socket.

Figure 2 shows the T7316 installation procedure. See [“Installing a T7316 telephone \(North America\)”](#) on page 21.

Figure 2 Installing a T7316 telephone (North America)

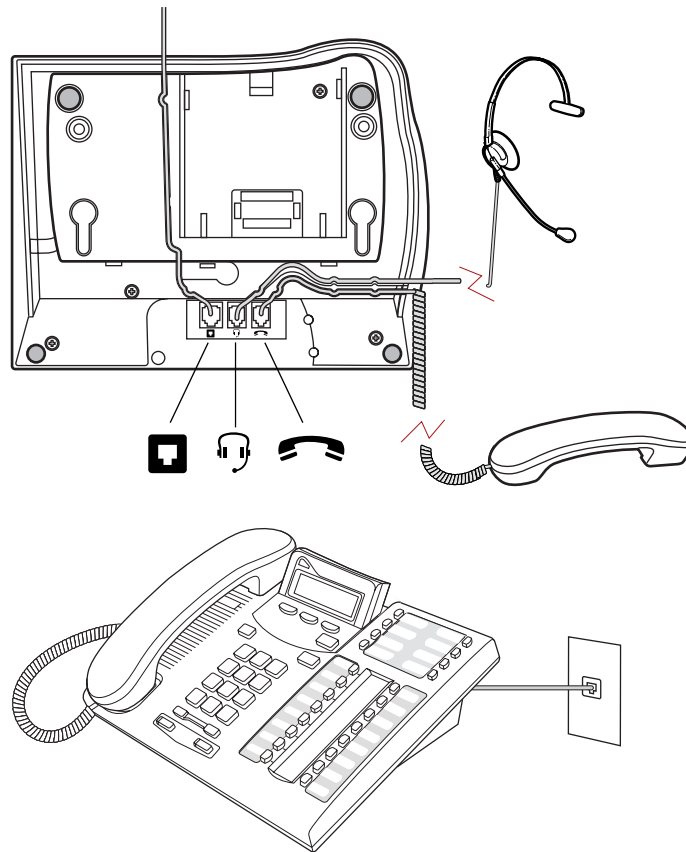

Figure 3 shows the T7316 and stand wall mounting procedure. See [“Mounting a T7316 telephone with a stand on the wall”](#) on page 22.

Figure 3 Mounting a T7316 telephone with a stand on the wall

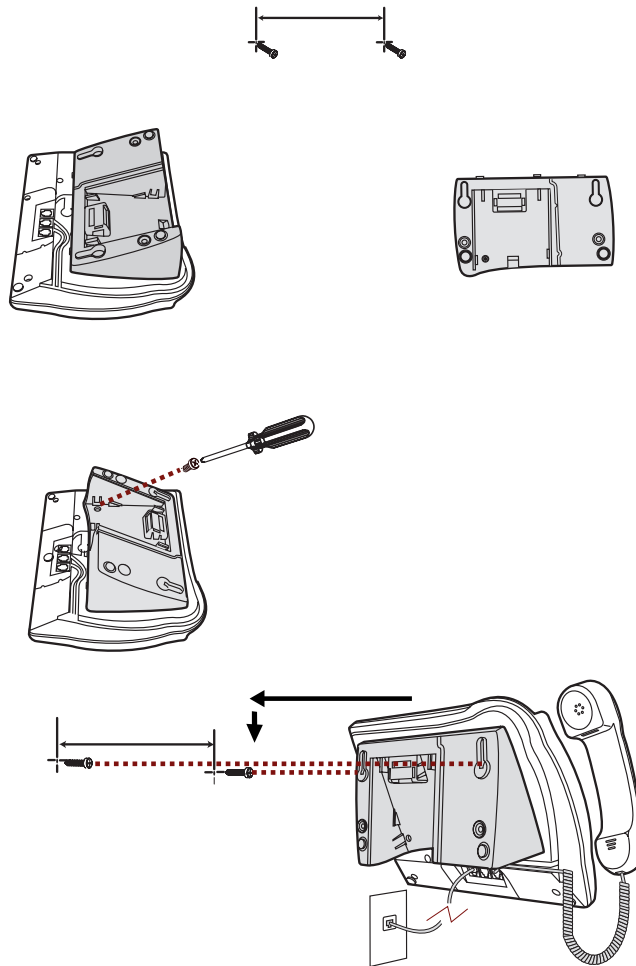
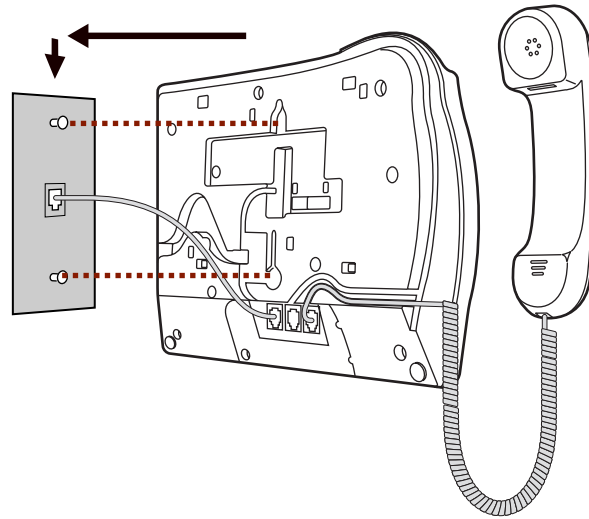

Figure 4 shows the T7316 without a stand wall mounting procedure. See [“Mounting a T7316 telephone without a stand on the wall”](#) on page 23.

Figure 4 Mounting a T7316 telephone without a stand on the wall

Name a telephone or a line

You can assign names to identify external lines, target lines, and your colleagues' telephones. During a call, the name (if programmed) appears on the telephone display instead of the external line number or internal telephone number of the caller. You need to start a Unified Manager session to program this feature. For more information about programming using Unified Manager, see the *Business Communications Manager Programming Operations Guide*.

Telephone names and line names can contain both letters and numbers, but cannot be longer than seven characters. You cannot use the # and * symbols.



Note: You can give the same name to a telephone and a line in your system. Use initials, abbreviations, or even nicknames to give each telephone a unique name to avoid confusion.

Extension numbers

Each telephone in the system has an extension number. The length of extension numbers in your system can range from two to seven digits. All numbers in your system are the same length. Your installer assigns the length of extension numbers, called the extension length. The default extension length is three.

To find out your internal number, use the Button Inquiry feature () from an intercom button. On the T7100 telephone, Button Inquiry shows your internal number followed by the function assigned to the memory button.

Line assignment

You can assign any of the lines in your system to any of your telephones. Your installer assigns lines to telephones. Assignments for lines are:

- appear only
- appear and ring
- ring only

Lines assigned to a telephone automatically have a line button on that telephone, when a button is available. The T7100 telephone has no line buttons.

Prime line

You can program your telephone to select an internal, or external line, or a line pool automatically when you lift the handset. This is your prime line.

Private line

A private line is limited to a selected telephone. You can pick up calls put on hold, or not answered on a private line, only at the prime telephone.

Target line

A target line routes a call directly to a selected telephone, or group of telephones. Target lines are only for incoming calls. A single incoming line can provide connections to several different target lines. Target lines allow each person or department in the office to have their own number without having a separate external line for each number.

Overflow call routing

If a call comes in to a target line that is busy, the system routes the call to the prime telephone for that target line. If there is no prime telephone assigned to the target line, or if you cannot direct a call to a target line, the call goes to the prime telephone for the external line.

Overflow routing for incoming calls uses the routing service programmed by your installer. Service must be active for overflow routing to operate. Overflow routing is not available in normal service.













Note: When you make a call and the programmed route is busy, you hear the expensive route warning tone and see a display indicating the use of an expensive route. To avoid using the normal, expensive route, release your call.

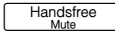

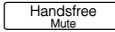

Because overflow routing directs calls using different line pools, a call might be affected by different line filters.

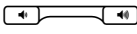
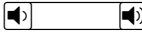
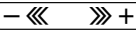
Telephone buttons

This guide shows the Business Series Terminals buttons. Table 1 shows which buttons to use on the different types of Nortel Networks telephones. See [“Telephone buttons” on page 25](#).

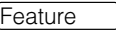
Table 1 Telephone buttons

Button Name	T7100, T7208, T7316	M7100, M7208, M7310, M7324	M7100N, M7208N, M7310N, M7324N
Feature		Feature	
Handsfree	Bottom right-hand button		
Mute			
Hold		Hold	
Volume Control			
Release		Rls	

You can enter , , or  and the code to use a feature. For example: Press  9  1 to access your mailbox.

The T7100 telephone works differently from other telephones on your system because it does not have line buttons. Where other telephones can require that you select a line button to answer a call, on the T7100 telephone you pick up the handset. Where other telephones require you to select a line button to take a call off hold, you press  on the T7100 telephone.

On T7100 telephones, you can answer a second call by pressing . Your active call is put on hold and you connect to the waiting call. You can have no more than two active calls at one time.

The T7100 telephone does not have a  button.

Table 2 shows the buttons and their functions for each telephone. See [“Telephone button functions” on page 25](#).

Table 2 Telephone button functions

1 Dial pad	Used for dialing numbers and for entering numbers and letters when you are programming.
2 Display	Shows instructions for calling and programming.
3 Display buttons	The current use appears on the display above each button.
4 Memory buttons	Dial a number or feature code stored on the button.
5 Feature button	Allows you to enter a feature code while using or programming the telephone.
6 Hold button	Puts an active call on hold.
7 Release button	Hangs up an active call or ends programming.

For more information about telephone buttons, refer to your Telephone User Card.

One-line and two-line displays

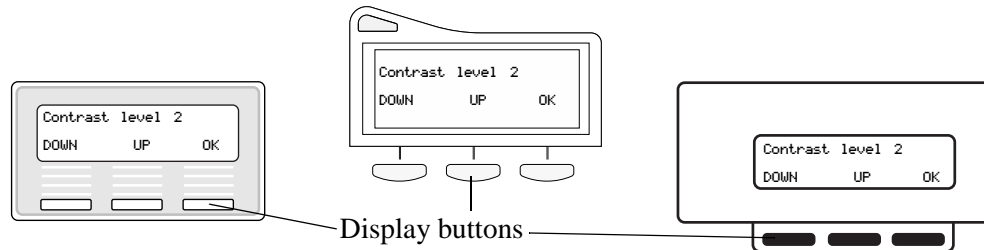

The T7100 and T7208 telephones have a one-line display. The T7316 and M7324(N) telephones have a second line on the display which shows the functions of the three buttons below it. Figure 5 shows the different types of telephone display buttons. See [“Display buttons”](#) on page 26.

Figure 5 Display buttons



Some display buttons, such as TRANSFR and ALL, are shortcuts that are only available on a two-line display. Other display buttons, such as OK and SHOW, perform a function necessary to proceed. Table 3 shows display button functions and dial pad buttons on a one-line display telephone. See [“Substitutes for buttons on a one-line display telephone”](#) on page 26.

Table 3 Substitutes for buttons on a one-line display telephone

Display buttons	Dial pad buttons on a T7100 and T7208 telephones
OK	 or <input type="text" value="Hold"/>
QUIT	 or <input type="text" value="Rls"/>
ADD	<input type="text" value="*"/>
SHOW	<input type="text" value="#"/>
CANCEL	<input type="text" value="#"/>
VIEW	<input type="text" value="#"/>
OVERRIDE	<input type="text" value="#"/>
BKSP	<input type="text" value="←"/> or <input type="text" value="▶"/>

All examples in this guide show the two-line display.

Buttons under the display

The three display buttons are for telephone features. The programming session determines what the display shows and what each button does. Some display instructions are OK, CHANGE or COPY. In this guide, display button instructions appear underlined.

Memory buttons

You can use memory buttons as answer, autodial, line, and programmed feature buttons. Line, intercom and answer buttons must have indicators. The T7316, T7208 and M7324(N) telephones have memory buttons with indicators. The T7316 telephone also has memory buttons without indicators. There is a single memory button, without an indicator, on the T7100 telephone.

Program buttons

Press the  button on the telephone followed by an activation code for personal programming. For a summary of all the Feature button programming, refer to [Appendix A, “Feature Codes,”](#) on [page 129](#).

Chapter 2

Answer calls

There are three indications of an incoming call:

- ringing
- a line button flashing
- a message on the display

You do not always receive all three indications for any distinct call. For example, you can have a line set up not to ring at your telephone. If so, you see only a flashing line button. There are many possible combinations, depending on your system set up. For more information about the use of lines, see [“Line buttons” on page 42](#).

Ring types

There are several different types of ring.

A double beep every ten seconds	A call is camped to your telephone.
A long single ring	There is an external call on the line for you.
A shorter double ring	There is an internal call on the line for you, or a call is being transferred to you.
A brief single ring	A call arriving on an external line is redirected to a telephone outside of your system. You cannot answer this call.
Three beeps descending in tone	You are receiving a priority call.

Distinctive Line Ring

There are four Distinctive Ring patterns (DRP) for incoming calls.

DRP 4	Highest priority
DRP 3	2nd highest priority
DRP 2	3rd highest priority
DRP 1	Lowest priority



Call Ringing

When more than one call rings at a telephone, highest priority DRP rings through first.

Call Answering

When more than one call rings at a telephone, the user lifts the handset and automatically answers the call with the highest priority.



Note: External calls have a higher priority than internal calls. You cannot press  *  to change the ring type on a telephone when the Distinctive Line Ring feature is in service.

For more information about the Distinctive Line Ring feature, refer to the *Business Communications Manager Programming Operations Guide*.

Line buttons

For each line assigned to your telephone, you have one line button. Press the flashing line button to select the line you want to answer. Having several line buttons gives you immediate access to more than one line.

The T7100 telephone has two intercom paths, instead of line buttons, to answer calls. You can assign two lines to each T7100 telephone. You can press  to switch between two calls, one active and one on hold.

What line indicators mean

▲ Flashing on and off for equal lengths of time	There is an incoming call on the line.
▲ Flashing on and off more quickly	You have placed a call on hold.
▲ Flashing on for longer than off	A person has put a call on hold on that line.
▲ On, but not flashing	You are connected to the call on that line or the line is in use.
Off	The line is free.

Information about a call on the display

If you subscribe to Call Display services from your local telephone company, one line of information about an external caller appears on the display after you answer a call. Depending on the setting and the external information available, either the caller name or telephone number appears on the display. When you transfer an external call to another telephone in your system, the same information appears on the recipient's telephone display.

Depending on the services you subscribe to, Call Display information can contain up to three parts:

- the name of the caller
- the number of the caller
- the name of the line in your system that the call is on

For each telephone, you can determine which information appears on the display first.

Call Display information becomes available between the first and second ring of an incoming call. If you answer before the Call Display information appears on your display, press **[☎] [8] [1] [1]** to view the line number or line name. To use logging features with Call Display, see [“Call Log” on page 77](#).

Call Information for a specific call

Call Information allows you to see information about incoming calls. This information is more detailed than the Call Display information you can receive automatically. For external calls, you can see the caller name, telephone number, and the line name. For an internal call, you can see the caller name and the internal number. You can see information for ringing, answered, or held calls.

Call Log shows the same information as Call Information, with the date and time of the call, and the number of times the caller called.

View Call Information before or after answering

To find out who is calling or to view information about your current call:

- 1 Press **[☎] [8] [1] [1]**.
- 2 Press **[#]** or **VIEW** for more information about an external call.

Call Display information appears between the first and second ring of an incoming call. If you answer before the Call Display information appears on your display, and you press **[☎] [8] [1] [1]**, you see only the line number or line name.

View Call Information for a call on hold

- 1 Press **[☎] [8] [1] [1]**. The display shows **▲ Select a call**.
- 2 Select the line on hold. Information about the call appears on the display.
- 3 Press **[#]** or **VIEW** to display more information about an external call.



Note: If your telephone automatically shows Call Display information for a call, press **[☎] [8] [1] [1]** before you press **[#]** or **VIEW** for more information about the call.

Make Call Display information appear automatically at a telephone

Each telephone that rings for an external line can show Call Display information for that line. After answering a call, Call Display information appears on the display of the telephone that answered the call. Your installer or customer service representative can program telephones to have automatic Call Display.

Change which call information appears first

If the information is not available from your telephone company, you can see Unknown name or Unknown number on the display. If the caller blocks that information you can see Private name or Private number on the display.

You need to start a Unified Manager session to program this feature. For more information about programming using Unified Manager, see the *Business Communications Manager Programming Operations Guide*.

Priority Call

If you receive a priority call and your telephone has no free internal line buttons, you cannot transfer the priority call, you must accept or release it.

Answer calls at a prime telephone

The prime telephone is normally the attendant's telephone. The installer or customer service representative programs a prime telephone for a line. Calls not answered at their normal destinations transfer to the prime telephone. Business Communications Manager allows for a prime telephone for each line if needed. The prime telephone display gives information about the call, as in the following examples.

DND from 221 The person at telephone 221 has forwarded a call to you using Do Not Disturb.

DND transfer The system has transferred a call to you from a telephone with Do Not Disturb turned on.

DRT Line001 No person answered this call so the system transferred it to you.

Line061 callback
CALLBCK A person camped, parked or transferred a call on line 061, but no one has answered the call. Press CALLBCK or the line button to connect to the call.

Line061 to prime There is no telephone that can receive a call on line 061 so the system has transferred it to you.

Line002>Line052 The call coming in on line 002 for target line 052 has come to you because Line 052 is busy.

For other displays, see [Appendix B, “Common display prompts and error messages,”](#) on page 137.

Central answering position (CAP) module

A CAP module is an add-on device that provides 48 additional memory or line buttons. You can connect one or two CAP modules to the telephone to increase the number of lines it can handle. A CAP can monitor system telephone status, answer external calls on up to 120 lines, and send up to 30 messages to other system telephones.

A central answering position (CAP) is an M7324 or M7324N telephone and a CAP module(s) that your installer or customer service representative programmed as a CAP. You can have up to five telephones programmed as CAPs connected to Business Communications Manager. The CAP is best as the prime telephone and direct-dial telephone for the lines and telephones. Refer to [“CAP module with M7324 and M7324N telephones”](#) on page 34.

Figure 6 CAP module with M7324 and M7324N telephones

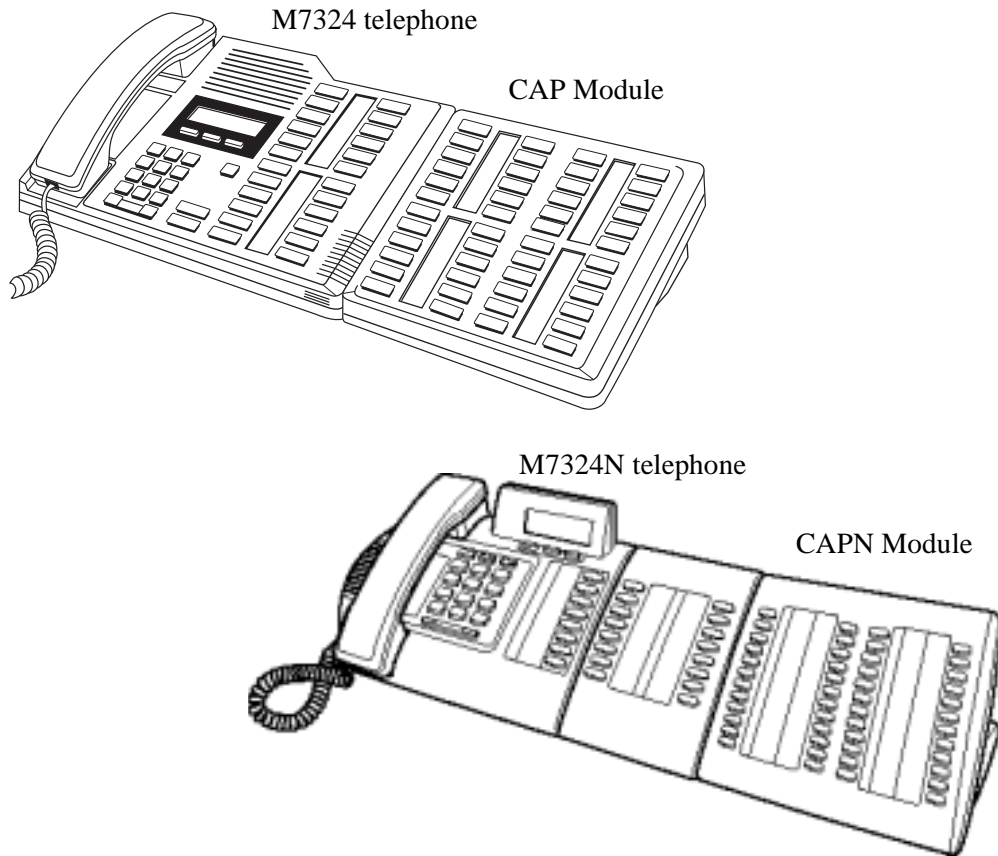

Customize your CAP module

When a CAP module is first plugged into your telephone, some of the module buttons are automatically programmed to dial an internal number. You can program any of the buttons on your CAP module that do not select lines to dial internal or external numbers automatically.

If your installer has programmed the CAP module for your system, you can move external lines to the CAP module by using **[Line]** **[*]** **[8]** **[1]**. See [“Move line buttons” on page 90](#).

You can program features on CAP module buttons. See [Chapter 4, “Time-saving features,” on page 49](#) and [Chapter 9, “Customize your telephone,” on page 83](#) for information about programming memory buttons. You cannot assign any buttons on a CAP module as answer buttons.

Monitor telephones with the CAP module

The indicators **▲** next to internal autodial buttons on your CAP module show the status of the telephones in your system.



The indicator is on when the telephone has:



- an active call
- Do Not Disturb turned on

The indicator is off when a telephone has:

- no active call
- a call on hold and no other active call

Release button

Press  to end a call. You do not have to put the handset down.  also ends feature programming.



While you are on a call, do not press  to end a feature you are using. If you do, you disconnect the call. Use  instead.

Pick up a call ringing at another telephone

You can answer a call ringing at another telephone by using Directed Pickup or Group Pickup.

Directed Pickup

You can answer any telephone that is ringing in your system.

- 1 Press   .
- 2 Enter the internal number of the ringing telephone. You cannot use Call Pickup to answer private lines.



Answer the telephone that has a flashing indicator for the call, or use Trunk Answer. You can answer a call that is transferred to an intercom button on another telephone. When the auxiliary ringer is ringing, but the call is not ringing at a telephone, you cannot answer the call using Directed Pickup.



Note: Directed Pickup can retrieve calls that are ringing on an Answer extension. Although you can enter the extension number of the telephone you hear ringing, it is possible the calls you are answering are from another telephone.

Group Pickup

Your system can support nine pickup groups. As a member of a pickup group, you can pick up a call that is ringing at any telephone in your pickup group.

Press    to pick up.

You cannot use Group Pickup to retrieve a camped call.

With more than one incoming call at a telephone in a pickup group, a call ringing on an external line is answered first, followed by calls on the prime line, and last, calls on intercom lines.

Change a telephone's pickup group

To place and retrieve telephones in and out of pickup groups, you need to start a Unified Manager session to program the feature. For more information about programming using Unified Manager, see the *Business Communications Manager Programming Operations Guide*.

Already joined	You are connected to the telephone that made the call you are trying to pick up. This display appears if you are on a call to a colleague, your colleague dials the number of a telephone in your pickup group, and you try to pick up that call.
Pickup denied	There is no call to pick up, or the call has been answered or you have tried to pick up a call on a person's private line.
Pickup:	Enter the internal number of the telephone that is ringing. (You can use an internal autodial button to do this.) If you decide not to answer a ringing call after you have activated Directed Pickup, press <input type="button" value="ⓧ"/> .

Trunk Answer

The Trunk Answer feature allows you to answer a ringing call in any area in the system from any telephone in the system. The line you are answering does not have to appear or ring at the telephone you are using.

Trunk Answer works only with calls that are ringing on lines for which a Ringing Service schedule is active, and if your installer or customer service representative enabled Trunk Answer. If there is more than one incoming call on lines in a Ringing Service, the Trunk Answer feature picks up the external call that has been ringing the longest.

Line denied	You have tried to pick up a call on a person's private line.
Pickup denied	The call that is ringing is on a line that is not in a Ringing Service.

Answer buttons

You can use an answer button to monitor calls on another person's telephone. All calls to the monitored telephone appear on the Answer button.

Answer buttons help attendants to monitor incoming calls for one or several other people. For example, an attendant can have line appearances for three different managers on the answer buttons of the telephone.

When an attendant answers a call for manager A the appearance stops at that manager's set. This flexibility allows for another (simultaneous) call to come in on the same line. The same is true for manager B and manager C. When incoming call traffic increases, the calls can route to a Hunt Group to optimize call handling. For more information about Hunt Groups see [Chapter 10, "Hunt Groups,"](#) on page 93.

The Answer button setting in Feature settings programming allows you to determine what types of calls ring at the telephone. Your options are:

- basic
- enhanced
- extended

For more information about programming Answer buttons, see the *Business Communications Manager Programming Operations Guide*.

T7100 telephones have no Answer buttons assigned to monitor other sets, but you can monitor them.

You cannot make calls using Answer buttons.





If two or more calls are ringing at a person's telephone, the first call appears on the attendant's Answer button. Any additional calls appear on intercom buttons, if they are available.



Note: More than one attendant can have an Answer button for a single telephone, allowing two or more attendants to handle calls for a busy person.





Each telephone can handle calls for up to eight other people using a separate Answer button for each person.

Listen to a call as a group

To allow people in your office to listen in on a call using Group Listening, press    .

You hear the caller's voice through your telephone's speaker. Continue to speak to the caller through the telephone handset. Your telephone's microphone is off, so the caller does not hear people in your office.

Cancel Group Listening

Group Listening cancels automatically when you hang up, or when you press  #   



Note: Keep the handset away from the speaker, or you can hear feedback. The higher the volume, the more the feedback. Press  to prevent feedback when hanging up.

Chapter 3

Make a call

The following are different ways to make a call, depending on the programming and the type of call:

- Pick up the handset and dial. Business Communications Manager supports three methods of dialing. See [“Select how you dial your calls” on page 42](#).
- Pick up the handset, press a line button, and dial (if the call is not on your prime line).
- Press **[M]** and dial (to talk without using the handset). See [“Handsfree and Mute” on page 97](#).
- Press a line or intercom button, then press the handsfree button and dial (to talk without the handset. The speaker is active and the microphone is muted until you select the handsfree button or pick up the handset).
- Press a line or intercom button and dial (to talk without the handset and if Automatic Handsfree is programmed on your telephone).
- Use one of the features that make dialing easier. See [Chapter 4, “Time-saving features,” on page 49](#).

221 busy
PRIORITY LATER

The telephone you have called has no internal lines available. Press **LATER** to use the Ring Again or Message features or press **PRIORITY** to make a priority call.

9_
QUIT BKSP

You are dialing using Pre-dial. To erase an incorrect digit, press the left end of **[←]** or **BKSP**. When the number is complete, select a line or lift the handset.

95551234
TRANSFR

This prompt remains on your display while you are on a call you have dialed. To transfer the call, press **TRANSFR**.

Already joined

Your telephone is connected to the telephone you are trying to call. Check your active line buttons, and return to that call.

Calling 221
PRIORITY LATER

Wait for the telephone to be answered. If no one answers, press **LATER** to use the Ring Again feature ([“Ring Again” on page 44](#)) or Message feature ([“Messages” on page 71](#)), or press **PRIORITY** to make a priority call.

Can't ring again

You cannot use Ring Again on your current call. You can use Ring Again while you have a busy signal on an internal call or line pool request or while an internal call is ringing.

Do not disturb
PRIORITY LATER

The telephone you are calling has Do Not Disturb turned on. Press **LATER** to use the Ring Again or Messages features, or press **PRIORITY** to make a priority call.

Expensive route	You have dialed a number, but the least expensive route programmed for the system is busy. Unless you release the call, the number goes through on a more expensive route.
Hidden number	The last number you dialed or the number you saved for Saved Number Redial was a speed dial number that displayed a name instead of the number. You dialed the number correctly, but it is not visible.
Line denied	You have tried to use another person's private line.
Line061 TRANSFR	Enter the digits of the number you want to dial.
No last number	You have not dialed an external telephone number since the last power interruption or system reset.
No line selected	Either you have no prime line or your prime line is busy. Select a line manually before dialing.
Not in service	You have entered the number of a telephone that is not in service.
On another call LATER	The telephone you have called is on another call. Press <u>LATER</u> to use the Ring Again or Message features.
Restricted call	System programming has a restriction configured for the call you are trying to make. A possible reason is time-of-day restrictions for some calls.
Ring Again? YES NO EXIT	Press <u>YES</u> to use Ring Again. Press <u>NO</u> to send a message. See "Messages" on page 71 and "Turn on Ring Again" on page 44 .
Select a line	Either you have no prime line, or the prime line is in use, or the line programmed for an autodial number, speed dial number, or Hotline is in use. Select a line and dial again.
Send message? YES NO	Press <u>YES</u> to send a message. See Messages.

Denied in Admin [redacted] The Last Number is not allowed.

For other displays, see [Appendix B, “Common display prompts and error messages,”](#) on page 137.

Line pools

A line pool allows each telephone access to external lines from a group (or pool) of external lines.

To access a line pool:

- press an intercom button and enter a line pool access code
- press a memory button programmed with the line pool feature code and a line pool access code

A line pool is a group of external lines shared by many telephones. You can use a line in a line pool to make an external call.



The system can support 15 line pools plus six PRI pools, and depending on system programming, a telephone can access any number of these line pools.

A line pool access code is the number you dial to get a line pool. The access code can be up to four digits long. You can have several different line pools for your system, each one giving you access to a different set of external lines. Line pools is one way of sharing lines across telephones in a system.

Your installer programs the access codes for line pools and gives each telephone access to a line pool.

Everyone in the office can have a list of the access codes for line pools their telephones can use.

Use a line pool to make a call

1 Press   .

2 Enter a line pool access code.

If you have a free internal line, you can make a call using a line pool without entering the feature code first.

1 Select an internal line (intercom).

2 Dial the line pool access code.



Note: If no lines are available in the line pool, you can use Ring Again at the busy tone. The system will inform you when a line in the line pool becomes available. See [“Ring Again”](#) on page 44.

Program a line pool feature code

When you program a button with the line pool feature code, you must enter a line pool access code after the feature code. The programmed line pool button accesses a specific line pool, not the line pool feature. See “[Programming feature codes](#)” on page 85 for more information.

If you program a button with an indicator to access a line pool, the indicator for the line pool button turns on when all the lines in a line pool are busy. The indicator turns off when a line becomes available.







Line buttons

There is one line button for each line assigned to your telephone. Press the line button to select the line you want to answer or use to make a call. As you have several line buttons, you can access more than one line.

The T7100 telephone has two intercom paths, instead of line buttons, to answer and make calls. A T7100 can have two lines. You can press  to switch between two calls, one active and one on hold.

Select how you dial your calls

To select a dialing mode:

- 1 Press    .
- 2 Press  or **NEXT** until the dialing mode you want appears.
- 3 Press  or **OK** to select the dialing mode.

You cannot program the dialing modes feature code on a memory button.

Standard dial

Standard dial allows you to make a call by selecting a line and dialing the number. If you have a prime line, it is selected automatically when you lift the handset or press the handsfree button.

You cannot use Standard dial on a T7100 telephone unless you pick up the handset first. If you have a T7100 telephone, use the Automatic dial or Pre-dial feature for on-hook dialing.

Automatic dial



Automatic dial allows you to dial a number without selecting a line. Your prime line is selected when you start dialing a number. Automatic dial does not work if your telephone has no prime line or when your prime line is in use.

Telephones connected to an Analog Terminal Adaptor (ATA2) or an Analog Station Module (ASM) cannot use Automatic dial.

Pre-dial

Pre-dial allows you to enter a telephone number, check it, then change it before making the call. The call does not dial until you select a line or line pool, or pick up the handset. You can pre-dial both external and internal numbers. You must, however, select the correct type of line (external or internal) for the type of number you have entered.



Note: If your telephone starts ringing while you are pre-dialing a number, you can stop the ringing by turning on Do Not Disturb (  ). Do Not Disturb entered while dialing does not affect the numbers you are entering. You cannot pre-dial a telephone number if all the lines on your telephone are busy.

Receive a busy signal on an internal call

When the internal number you dialed is busy there are three possibilities:

- Priority Call
- Ring Again
- Message

Priority Call



If you get a busy signal or a Do Not Disturb message when you call someone in your office, you can interrupt their call by using the Priority Call feature. Use this feature for urgent calls only.

Program a telephone to make priority calls

You need to start a Unified Manager session to program this feature. For more information about programming using Unified Manager, see the *Business Communications Manager Programming Operations Guide*.

Make a priority call

To make a priority call:

- 1 Press   .
- 2 Wait for a connection, then speak.

A person who receives a priority call while on another call has eight seconds to accept or block the call. For information about blocking calls see [“Stop calls” on page 96](#). If the person does nothing, the priority call feature puts their active call, including conference parties, on Exclusive Hold and connects your call.

When you make a priority call, the display may show the following:

Call blocked	You tried to place a priority call to another telephone in your system. The person you called has blocked your call. Try to call later.
Please wait	The party you are calling has eight seconds to decide to accept or reject your priority call.
Priority denied	The telephone you are calling is receiving a priority call at the same time or cannot receive priority calls.

You can make a priority call only while your telephone display shows the following:

221 busy
PRIORITY LATER

Calling 221
PRIORITY LATER

Do not disturb
PRIORITY LATER

On another call
PRIORITY LATER

Ring Again

Use Ring Again when you call a person on your system and their telephone is busy or there is no answer. Ring Again can tell you when they hang up or next use their telephone. You can use Ring Again to tell you when a busy line pool becomes available.

Turn on Ring Again

To turn on Ring Again, press **[e]** **[2]** before you hang up.

Using Ring Again cancels any previous Ring Again requests at your telephone.

Cancel Ring Again

Press **[*] # 2** to cancel a Ring Again request.

Can't ring again

You cannot use Ring Again on your current call. You can use Ring Again while you have a busy signal on an internal call or line pool request, or while an internal call is ringing.

Ring Again?

YES NO EXIT

Press **YES** to use Ring Again. Press **NO** if you select to send a message.

Message

When using Priority Call and Ring Again don't work, you can leave a message on the person's display. For more information, refer to [“Messages” on page 71](#).

Create a Conference Call

You can talk to two people at the same time.

- 1 Make sure you have two calls, one active and one on hold.
- 2 Press **[*] 3**.
- 3 Press the held line. (This action is automatic on the T7100 telephone.)

You can create a conference when you are on a call:

- 1 Put the call on hold. (This action is not necessary when the Automatic Hold feature is available on your system.)
- 2 Make a second call.
- 3 Press **[*] 3**.
- 4 Press the held line.

Only the person who established the conference can use the procedures described in this section.



Note: You can create a conference by releasing privacy on a call. See [“Turn Privacy on or off for a call” on page 96](#).







Disconnect one party

You can disconnect one party from a conference and continue talking to the other.







On a T7208, T7310, T7316 or M7324(N) telephone:

- 1 Press the line button of the call that you want to disconnect. The second call is automatically put on hold.
- 2 Press  to disconnect the first call.
- 3 Press the button of the held line to reconnect with the second call.

On a T7100 telephone:



- 1 Press    to put the first call on hold.
- 2 Press  to put the second call on hold.
- 3 Press  to disconnect the second call.
- 4 Press  to reconnect with the first call.

or

- 1 Press    and then press  to put the second call on hold.
- 2 Press  to disconnect the first call.
- 3 Press  to reconnect with the second call.

Separate holding of two calls

For all system telephones except the T7100 telephone, you can place the two people in a conference call on hold separately, so that they cannot talk to each other.

- 1 Press the line button of one call. The other call is automatically put on hold.
- 2 Press . The second call is put on hold.
Now you can re-establish the conference.
- 3 Take one call off hold.
- 4 Press  .
- 5 Take the remaining call off hold.

Put a conference on hold

You can put a conference on hold, allowing the other two people to continue speaking to each other by pressing .



You can rejoin the conference by pressing either of the held line buttons.

For the T7100 telephone, press .







Split a conference

You can speak with one caller while the other call is on hold. You can switch between calls using .

On a T7208, T7310, T7316 or M7324(N) telephone:

- 1 Press the line button of the caller with whom you want to speak. The other call is automatically put on hold.
- 2 Press   to re-establish the conference.

On a T7100 telephone:

- 1 Press   . The first call is put on hold.
- 2 Press  to switch between calls.
- 3 Press   to re-establish the conference.

Leave a conference call

You can remove yourself from a conference, and connect the other two callers.

Enter the Transfer feature code   .

When you remove yourself from a conference using the Transfer feature, and both calls are from outside your system, one of the calls must have come to you on a disconnect supervised line, or the call disconnects.

3 parties only You are trying to add a fourth party to your conference call, or to join two conferences together. Release one call from the conference before adding another, or keep the two conferences separate.

Conference busy You have tried to make a conference call, but your system is handling its maximum number of conference calls.

Line001 221
TRANSFR You are on a conference with the two lines or telephones shown. You can drop out of the conference and leave the other two parties connected (Unsupervised Conference) by pressing **TRANSFR** or entering the Transfer feature code.

Press held line You have activated the Conference feature with one call active and another on hold. Press the held line to bring that person into the conference.

For other displays, see [Appendix B, “Common display prompts and error messages,”](#) on page 137.

Chapter 4

Time-saving features

This chapter shows you some time-saving features such as:







- Autodial
- Last Number Redial
- Speed Dial
- Saved Number Redial

Autodial

You can program memory buttons for one-touch dialing of internal or external telephone numbers. You cannot use buttons for lines, answer or Handsfree/Mute as autodial buttons.

If the power to your Business Communications Manager system is off for more than three days, autodial numbers and some other system programming can be lost from the memory.

To add an autodial button:

- 1 Press    to program an external number or    for an internal number.
- 2 Select a button and then dial the number.

When programming Autodial you can use the following:

- Last Number Redial
- Saved Number Redial
- destination codes (select an intercom button as the line)

Select a line for Autodial

To select a line for an external number, press the line or intercom button before you enter the number. To select a line pool, press a programmed line pool button, or press an intercom button, and enter a line pool access code.

If you select a line before pressing the autodial button, the call goes out on that line instead of the line that is part of the autodialer programming.





For the T7100 telephone, program an external autodialer by using a line and not a line pool.



Note: If you do not include a line selection in an autodial number, the call uses your prime line (if you have one).

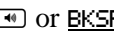

Use intercom as the line for Autodial

If you press an intercom button as the line for an external autodial number, you must include a valid line pool access code or a destination code. If access codes for line pool or destination codes change, remember to reprogram autodial numbers.

<p>987_</p> <p>QUIT BKSP OK</p>	<p>Continue to enter digits until the number is complete. Press  or  or BKSP to erase an incorrect digit. Press  or OK when you finish.</p>
<p>Autodial full</p>	<p>The memory allocated to autodial numbers in your system is full.</p>
<p>Button erased</p>	<p>While programming external Autodial, you erased the button by pressing  or OK before entering any digits.</p>
<p>Enter digits</p> <p>QUIT OK</p>	<p>Enter the number you want to program (selecting the line first if necessary) exactly as if you were making a call.</p>
<p>Intercom #: _</p> <p>QUIT</p>	<p>Enter the internal telephone number you want to program.</p>
<p>Invalid number</p>	<p>You are programming an internal autodial button and have entered a number that is not an internal number on your system. Enter a valid internal number. If the number you are entering is a destination code, use external autodial.</p>
<p>Press a button</p> <p>QUIT</p>	<p>Press the memory button you want to program.</p>
<p>Program and HOLD</p>	<p>Enter the number you want to program on the button, then press .</p>
<p>Program and OK</p> <p>QUIT OK</p>	<p>Enter the number you want to program on the button, then press  or OK. You can include a line or line pool selection in an autodial sequence by selecting the line before entering any digits.</p>
<p>Programmed</p>	<p>The number is correctly stored on the button.</p>





For other displays, see [Appendix B, “Common display prompts and error messages,”](#) on page 137.

Last Number Redial

Press   to redial the last external number you dialed.

Last Number Redial records a maximum of 24 digits.



Note: If you have a Last Number Redial button programmed, use Button Inquiry (  ), then press the Last Number Redial button followed by () to check the last number before you dial it.

Prevent Last Number Redial

Last Number Redial can be restricted at individual telephones.

You need to start a Unified Manager session to program this feature. For more information about programming using Unified Manager, see the Business Communications Manager Programming Operations Guide.

Hidden number

The last number you dialed was a speed dial number that displayed a name instead of the number. The number dials correctly, but does not appear on the display.

No last number

You have not dialed an external telephone number since the last power interruption or system reset.



Note: You can copy a number on an autodial button using Last Number Redial.

Speed Dial

Business Communications Manager provides two types of speed dialing:

- system
- personal

System Speed Dial programming allows you to assign two-digit speed dial codes to the external numbers called most often. Personal Speed Dial programming allows users to program their own speed dial numbers.

Speed dial numbers are subject to the same restriction filters as normally dialed numbers. Your installer can program system speed dial numbers to bypass dialing restrictions.

To make a speed dial call

- 1 Press   to quickly dial external telephone numbers that programmed to speed dial codes.

- 2 Enter the appropriate two-digit speed dial code.

System Speed Dial codes

System Speed Dial codes are numbered from 01 to 70. The installer assigns numbers to System Speed Dial codes for the all the system.



Note: There is no difference between using User Speed Dial and using System Speed Dial. Only the programming is different.

Personal Speed Dial

To add or change a Personal Speed Dial number on your telephone:

- 1 Press * 4 .
- 2 Enter a two-digit code from 71 to 94 that you want to relate with a telephone number.
- 3 To include a line selection for this number, press the line or intercom button. To select a line pool, press a programmed line pool button, or press an intercom button and enter a line pool access code. For the T7100 telephone, you can only select a line pool.
- 4 Enter the number you want to program.
- 5 Press or OK.

01:9_
CANCL BKSP OK

Continue entering the number you want to program. You can change the number by pressing BKSP or . When you are finished, press or OK.

Enter digits
QUIT OK

Enter the telephone number you want to program exactly as if you were dialing it normally. When you are finished, press or OK.

Invalid code

You have entered a code outside the code range (01-70 for system, 71-94 for personal).

No number stored

There is no number stored on the speed dial code you have dialed.

Program and HOLD

If you want to program a line or line pool selection for this speed dial number, select the line or line pool. If not, enter the telephone number exactly as if you were dialing it normally. When you are finished, press .

Program and OK
QUIT OK

If you want to program a line or line pool selection for this speed dial number, select the line or line pool. If not, enter the telephone number you want to program exactly as if you were dialing it normally. When you are finished, press OK.

Select a line There is no line related with the speed dial number you are trying to use. Select a free external line or line pool and enter the speed dial feature code again.

Unknown number The system cannot dial the number stored. Reprogram the number.

For other displays, see [Appendix B, “Common display prompts and error messages,”](#) on page 137.

Saved Number Redial

You can save the number of the external call you are on (provided you dialed the call) so that you can call it again later. Each telephone can save one number at a time with Saved Number Redial, but not one number for each line.



Note: You can copy a number on an autodial button using Saved Number Redial.

Save a number

To save a number, press **[☎] [6] [7]** while you are on the call.

Saved Number Redial records a maximum of 24 digits.

Dial a saved number

To dial a saved number, press **[☎] [6] [7]** when you are not on a call.

If you have a programmed Saved Number Redial button, you can use Button Inquiry (**[☎] [*] [0]**) to check the last number before you dial it.

Prevent Saved Number Redial

Saved Number Redial can be restricted at individual telephones.

You need to start a Unified Manager session to program this feature. For more information about programming using Unified Manager, see the *Business Communications Manager Programming Operations Guide*.

- | | |
|-----------------|--|
| Hidden number | You have saved a speed dial number that displays a name instead of the number. The number dials correctly, but does not appear on the display. |
| No number saved | You have tried to save the number of an incoming call. You can only save numbers that you have dialed. |

Chapter 5

Handling calls

This chapter shows you how to:

- handle many calls at a time
- transfer calls
- park a call

Use Hold

You can put a call on hold by pressing .

When a call is on hold, the button indicator flashes on all telephones that have access to that line. Any of these telephones can retrieve the call.

On the T7100 telephone,  changes between two lines; one active, one on hold. The T7100 telephone cannot retrieve a call placed on hold by another telephone.

Retrieve a held call

You can connect to a call on hold by pressing the flashing line button of the held call.

Hold automatically

If a line is programmed with full autohold, you can switch from one call to another and have your calls put on hold automatically.

Press the line button of the second caller. The current caller is put on hold automatically.

Listen on hold

If your call is placed on hold, you can hang up the handset while you wait for the other person to return.

- 1 Press .
- 2 Hang up the handset.
- 3 Press the line button of the call. You can hear indications from the far end that you are on hold (for example, tones or music).

- 4 When the person returns, lift the handset to continue the conversation.



Note: With Automatic Handsfree assigned to your telephone, you can use the Handsfree/Mute feature instead of Listen on Hold.

Hold a call exclusively

You can put a call on Exclusive Hold so that you can retrieve it only at your telephone.

Press or . The line appears busy on all other telephones, and the call cannot be picked up by another person in the office.

On hold: LINENAM

You have placed one or more calls on hold. The name of the line held the longest appears on the display.

Call Queuing

If you have more than one call ringing at your telephone, you can select the call that has the highest priority by pressing .

Call Queuing answers incoming external calls before callback, camped, and transferred calls.

Transfer calls

Transfer allows you to direct a call to a telephone in your system, within the Business Communications Manager network, or external to your system.

- 1 To transfer a call, press .
- 2 Call the person to whom you want to transfer the call.
- 3 If you want to talk to the person, wait for the person to answer and speak to person before continuing.
- 4 When you are ready to complete the transfer, press or **JOIN**.

You cannot use Last Number Redial, Saved Number Redial, a speed dial code, Priority Call or Ring Again to dial the number for a transfer.

The way a private network call is routed determines if it is possible for the system to return a transferred call to you when the transferred call is not answered. When transferring a call to a private network destination, remain on the line until the person to whom you are transferring the call answers.

You cannot use the Line Pool feature code to access a line pool for a transfer. To use a line pool, use a programmed line pool button, or press an intercom button, and enter a line pool access code.

If an auxiliary ringer is programmed to ring for calls on an external line, and you transfer a call on that line without announcing the transfer, the auxiliary ringer rings for the transferred call.

Transfer external calls

If you transfer an external call to a busy telephone, or if there is no answer, the call automatically rings again at the telephone that performed the transfer. The display indicates that the telephone was busy or that no one answered.

When you transfer an external call to an external number, the external call you are trying to transfer must be an incoming call on a disconnect supervision line.

While on a conference call, you can leave the conference and connect two callers using the Transfer feature. If the other people are from outside the system, at least one of the callers must have called you and both of the calls must be on disconnect supervision lines.



Note: Transfer by Hold on DID lines is not supported. After answering a call, the line appearances on all other sets are free immediately to take other calls. This allows you to receive a greater number of calls. Use the Call Park feature to transfer a call.

In some conditions, you can experience lower volume levels when transferring an external call to an external telephone, or when transferring two external callers from a conference call.

Cancel a transfer

You can reconnect to the person you are trying to transfer before the transfer is complete.

- 1 Press # 7 0 or **CANCL**.
- 2 If you do not reconnect to your original call, press and then press the held line.

221>222
CANCL RETRY JOIN

You are talking to the person you want to transfer the call to. Press **RETRY** if you decide to transfer the call to another person. Press or **JOIN** to transfer the call.

221 no reply
CALLBCK

The person to whom you tried to transfer a call did not answer. Press **CALLBCK** or the flashing line button to reconnect to the call. On the T7100 telephone, lift the handset.

Do not disturb
CANCL RETRY JOIN

The person to whom you tried to transfer a call has Do Not Disturb active on their telephone. Press **JOIN** to transfer the call. Press **RETRY** to transfer the call to another person. Press **CANCL** or the flashing line button to reconnect to the call (on the T7100 telephone, press # 7 0).

Invalid number
CANCL RETRY

You entered an invalid internal number. Press **RETRY** and enter the number again.

Line061 hung up CANCL RETRY JOIN	The external caller you were transferring hung up before the transfer was complete.
Line061>221 CANCL RETRY JOIN	Press <u>JOIN</u> to transfer the call on line 061 to telephone 221. Press <u>RETRY</u> if, after talking to the person at extension 221, you decide to transfer the call to another person.
Not in service CANCL RETRY	The telephone to which you are trying to transfer a call is out of service.
Restricted call CANCL RETRY	You cannot transfer the call because of telephone or line restrictions.
Still in transfer CANCL RETRY	Complete the transfer in progress before you access a new feature, answer another call or select an outgoing line.
Transfer denied CANCL RETRY	Your transfer does not function for one of these reasons: All the resources needed to perform a transfer are in use. Try again later. You have tried to transfer an external call to another external party. Some restrictions apply. You cannot transfer your conference call.
Transfer to:2__ CANCL RETRY	Press <u>RETRY</u> if you entered the wrong internal number or if the person to whom you are transferring the call is not available.

For other displays, see [Appendix B, “Common display prompts and error messages,”](#) on page 137.

Camp-on

You can transfer an external call to another telephone when all the lines assigned to that telephone are busy.

1 Press .

2 Dial the number of the telephone to which you want to camp the call.

Camped calls appear on a line button on the receiving telephone, if one is available. If there is no line button available, you receive a message on the display and hear Camp-on tones.

Each telephone in your system can handle one camped call at a time.

221 DND CALLBCK	The person to whom you redirected a call has Do Not Disturb active on the telephone. The call has come back to you. Press the <u>CALLBCK</u> button or the line button to reconnect to the call. On the T7100 telephone, just pick up the handset.
Camp denied	You have tried to camp an internal call. You can camp external calls only.
Camp to: CANCL	Dial the number of the internal telephone to which you want to camp the call.
Camped: 221 CALLBCK	The telephone to which you camped a call did not answer the call. The call has come back to you. Press <u>CALLBCK</u> or the line button to reconnect to the call. On the T7100 telephone, just pick up the handset.
Line061 hung up	A call you camped has come back to you, but the caller hung up before you can reconnect.
Not in service CALLBCK	The telephone to which you have camped a call is out of service or is used for programming. The call has come back to you. Press <u>CALLBCK</u> or the line button to reconnect to the call. On the T7100 telephone, just pick up the handset.
Release a call	The line that the camped call is on is in use or that line does not appear at your telephone. Release the line or release an internal line.

For other displays, see [Appendix B, “Common display prompts and error messages,”](#) on page 137.

Call Park

When you park a call, the system assigns one of 25 codes for the retrieval of the call. These codes include the Call Park prefix, which can be any digit from 1 to 9, and a two-digit call number between 01 and 25. For example, if the Call Park prefix is 1, the first parked call is assigned Call Park retrieval code 101.

The system assigns Call Park codes in sequence, from the lowest to the highest, until all the codes are used. A round-robin method means the use of different codes ensures a call reaches the right person, especially when more than one incoming call is parked.

The highest call number (the Call Park prefix followed by 25) is used only by analog telephones or devices connected to the system using an ATA2 or an ASM. Analog telephones or devices cannot use the other Call Park codes.

Your installer programs both the Call Park prefix and the delay before parked calls return to the originating telephone. External calls parked for longer than the programmed delay return to your telephone.

Park a call

You can interrupt a call to retrieve it from any telephone in your system.

- 1 Press **[☎] 7 4**.
- 2 Press **PAGE** to announce the retrieval code on your telephone display.

Retrieve a parked call

- 1 Select an internal line. (On the T7100 telephone, pick up the handset.)
- 2 Dial the Call Park retrieval code.

Your system installer can disable Call Park.

Already Parked The person you were talking to has parked your call. You cannot park the same call.

No call to Park You have tried to use Call Park with no active call on your telephone. If the call you want to park is on hold, reconnect to the call before you park it.

Invalid number You have entered an invalid retrieval code.

No call on: 101 There was no call on the retrieval code you entered.

Park denied You have tried to park a conference call. Split the conference and park the calls separately. The person who retrieves the calls can reconnect the conference.

Parked on: 402 Record the code shown. Use Page (**[☎] 6 0**) or press **PAGE** to announce the call and its retrieval code.
PAGE **EXIT**

Parking full All available retrieval codes are in use. Transfer the call or take a message instead.

For other displays, see [Appendix B, “Common display prompts and error messages,” on page 137](#).

Callback

When you direct a call you have answered to another telephone, the system monitors the call to make sure it is answered. If no one answers the call within a set length of time, the system returns it to you.

Callback generates many different displays. Most occur after a set delay and are listed in the index. Some occur immediately if the telephone to which you direct a call is out of service or not available. These different displays are listed with the descriptions of the specific features such as Transfer or Camp-on.

Chapter 6

Forward your calls

If you leave your desk but want to receive calls at another location, you can forward your calls to an internal or external telephone.

Call Forward

When you use Call Forward, all calls go to the destination you select, regardless of Forward on busy (CFB) and Forward no answer (CFNA) feature programming.

To forward calls:

- 1 Press **[F]** **[4]**.
- 2 Enter the number of the telephone to which you want your calls forwarded.

To forward your calls to an external destination you must enter the route plus the dialing digits of the external telephone. For example, if you need to dial 9 for external calls, then you must enter 9 plus the dialing digits to forward your calls to an external number.

Alternatively, you can use Line Redirection to forward calls outside the system. Line Redirection takes priority over Call Forward.

Cancel Call Forward

Press **[F]** **[#]** **[4]** to cancel Call Forward.

To allow external destination programming you need to start a Unified Manager session. You must assign Program Allow redirect to Yes for each telephone. For more information about programming using Unified Manager, see the *Business Communications Manager Programming Operations Guide*.

If the telephone to which you forwarded your calls does not have the same external lines as your telephone, the forwarded calls appear on intercom buttons.

Forwarded calls do not ring but the line indicator flashes on the telephone. You can answer the call by pressing the button next to the flashing indicator.



Note: If you set up forward loops from one telephone to another in a circle, this can result in unanswered calls at any location.

Override Call Forward

When you call a person who has Call Forward to your extension, your call rings at that person's telephone.

Change the automatic Call Forward settings

The Call Forward feature allows for programming of calls not answered or when the line is busy. You can define the number of times the telephone rings before call forwarding occurs. Program this feature by starting a Unified Manager session.

Change Call Forward no answer

The Call Forward no answer feature redirects calls to another telephone in your system.

Line Redirection takes priority over Call Forward no answer.

For more information about changing Call Forward no answer using Unified Manager, see the *Business Communications Manager Programming Operations Guide*.

Change the delay before a call is forwarded

You can assign the number of times that an incoming call rings at your telephone before the system forwards the call. To estimate the delay time in seconds, multiply the number of rings by six. For more information see the *Business Communications Manager Programming Operations Guide*.

Call Forward on busy

The Call Forward on busy feature redirects calls to another telephone on your system when you are busy on a call, or when you have Do Not Disturb activated at your telephone. For more information about changing Call Forward on busy using Unified Manager, see the *Business Communications Manager Programming Operations Guide*.

Line Redirection takes priority over Call Forward on busy. The Call Forward feature or Call Forward programming do not affect calls redirected by Line Redirection.

Telephones that have Call Forward on busy active can receive priority calls. If you are busy on a target line call, another call to that target line redirects to the prime telephone for that target line.

DND on Busy

When you are busy on a call and a second call comes in, your telephone alerts you to the second call with a light ring. If you find this second call and ring is disruptive, you can prevent a second call by assigning Do Not Disturb (DND) on Busy to your extension.

If you use DND on Busy, the line indicator for an external incoming call flashes, but your telephone does not ring. Internal and private network callers hear a busy tone instead of ringing when you are on the telephone. External callers are transferred to the prime set used in your system. For more information about changing Do Not Disturb on Busy using Unified Manager, see the *Business Communications Manager Programming Operations Guide*.

Forward on Busy takes priority over DND on Busy.

If an external call uses a target line, the call is processed according to the programming of the target line. If the target line is busy, the caller hears a busy tone or routes the call to the prime set for the target line, even with DND on Busy programming for the telephone.

Call Forward and voice mail

If you want a voice mail system to pick up unanswered calls automatically:

- use the internal number of your voice mail as the destination when you program Forward no Answer and Forward on busy
- or
- if your voice messaging system or service automatically retrieves calls, make the ring delay greater than the delay used by your voice mail system

Forward denied

There are several reasons why you can get this message. For example, you cannot forward your calls to a telephone that has Call Forward programmed to your telephone.

Forward>221

Your calls are being forwarded to telephone 221.

CANCL

Not in service

Two or more telephones are linked in a forwarding chain, and one is out of service or used for programming.

For other displays, see [Appendix B, “Common display prompts and error messages,” on page 137](#).

Line Redirection



Line Redirection allows you to send your external calls to a telephone outside the office. You can decide to redirect all, or some of, your external lines.

Line Redirection takes priority over the Call Forward feature. If both features are active on a set, incoming external calls on redirected lines route to the indicated Selective Line Redirection (SLR) external destination. Incoming internal calls go forward to the indicated Call Forward destination.

You cannot use the Line Redirection feature on either a T7100 telephone or a telephone connected to an ATA2 or an ASM.

You redirect lines at a telephone, but after redirection programming, the lines redirect for the entire system.

You can redirect only lines that appear at line buttons on your telephone.

You can answer the telephone if it rings while you are programming Line Redirection; however, none of the call handling features are available until the feature times out. If you need to use a feature to process the call, quit Line Redirection programming by pressing . Do not press  or you disconnect the call you are trying to redirect.

While you are programming Line Redirection, you do not receive any indication of calls that do not actually ring at your telephone.

Be careful with redirection loops. If for example, you redirect your lines to your branch office and your branch office redirects its lines to you, you can create a redirection loop. If these calls are long distance, there can be charges.

In some conditions, callers can experience lower volume levels when you redirect calls to an external location.

Allow a telephone to redirect calls

You can turn a telephone's ability to redirect calls on and off.

You need to start a Unified Manager session to program this feature. For more information about programming using Unified Manager, see the *Business Communications Manager Programming Operations Guide*.





How Line Redirection is different from Call Forward

Call Forward forwards all calls that arrive at a selected telephone to an internal or external telephone. Line Redirection redirects only the lines you define, no matter which telephones they appear on, to a telephone outside the system.

Line Redirection takes priority over Call Forward.



Turn on Line Redirection

To turn on Line Redirection:

- 1 Press   .
- 2 Select the outgoing line to use for redirected calls.
- 3 Enter the number you need to redirect call to. To enter the telephone number to which you want to redirect calls, use one of the following methods:
 - Press an external autodial button.
 - Enter an external telephone number (using no more than 24 digits) then press  or **OK**.

- Press  or **OK** if the line you have selected as the outgoing line is a private network line that does not require you to dial digits.



4 Select the lines to redirect.

If you use **ALL** to redirect all your lines, ensure that you wait until all the lines on your telephone light up before pressing  or **OK**. If you press  or **OK** before all the lines light up, those lines not lit do not redirect.

You can continue to use the line selected for redirecting calls on other lines when the line is not busy on a redirected call. To avoid redirection failing because the selected line is in use, select a line pool with several lines in it. The system does not check that the number you give for line redirection is a valid one. If you redirect to an invalid number, redirection fails. To avoid a redirections failure, use an autodial button to enter the redirection number. You must program autodial buttons used for line redirection to use a specific line.

Cancel Line Redirection

To cancel Line Redirection:

- 1 Press  **#**  **8**  **4**.
- 2 Select the lines you no longer want to redirect.

Turn the redirect ring for a telephone on or off

You can program a telephone to ring briefly (200 milliseconds) when you redirect a call on one of its lines.

You need to start a Unified Manager session to program this feature. For more information about programming using Unified Manager, see the *Business Communications Manager Programming Operations Guide*



Note: If a telephone has redirect ring enabled, it rings briefly for redirected calls on one of its lines when another telephone has set up the line redirection.



The following displays appear when redirecting lines:

Intercom

You selected the intercom button as the facility on which to place the call. Enter a line pool code or a destination code.

Line Redirection

QUIT ADD REMOVE

Press  or **ADD** to begin redirection. Press  or **REMOVE** to cancel a previous redirection.

No line to use

You have one external line on your telephone, but you need a second line to perform line redirection. Redirect your external line using a line pool as the outgoing line.

<pre>Outgoing line _____ QUIT</pre>	You are trying to redirect a line and the line you have selected is the outgoing line you have selected as a destination. You cannot redirect a line to itself. Select another line.
<pre>Pool code: _ _____ QUIT</pre>	Enter a valid line pool access code.
<pre>Redir by 221 OVERRIDE</pre>	You have tried to redirect a line, but another person has redirected that line. Press <input type="checkbox"/> or <u>OVERRIDE</u> to override the previous redirection and redirect the line.
<pre>Redirect denied _____</pre>	You can redirect calls only on individual lines.
<pre>Select line out _____ QUIT</pre>	Select the line used to redirect calls out of the system.
<pre>Select line(s) QUIT ALL</pre>	Press the lines to redirect. To release a line selection, press the line to redirect again. Press <u>ALL</u> to redirect all your lines.
<pre>Select line(s) _____ ALL OK</pre>	Continue to press the lines to redirect. Press <input type="checkbox"/> or <u>OK</u> when finished.
<pre>Unequipped line _____</pre>	The line you are trying to redirect cannot be redirected because the hardware does not support redirection.

The following displays appear when canceling redirection:

<pre>Select line(s) QUIT ALL</pre>	Press the lines that no longer need redirection. The lines light up when pressed. After you cancel redirection for a line you cannot restore it by pressing the line again. Press <u>ALL</u> to cancel redirection for all your lines. When finished, press <input type="checkbox"/> or <u>OK</u> .
<pre>Select line(s) _____ ALL OK</pre>	Continue to press the lines that no longer need redirection. Press <input type="checkbox"/> or <u>OK</u> when finished.

For other displays, see [Appendix B, “Common display prompts and error messages,”](#) on page 137.

Chapter 7

Communicating in the office

There are several features for communicating in the workplace, such as:

- Page
- Message
- Voice Call

Page

The Page feature allows you to make announcements over the Business Communications Manager system using the telephone speakers, or a loudspeaker system if one is available.

Make a page announcement

To make a page announcement:

- 1 Press **[☎] 6 0**.
- 2 Enter a page type. Page types are:
 - 1** through the telephone speakers (internal page)
 - 2** through an external speaker (external page)
 - 3** both internal and external (combined page)
- 3 If necessary, select a zone. Press **0** for all zones.
- 4 Make your announcement.
- 5 Press **[☎]**.

Page Shortcuts

Instead of entering the Page feature code followed by the page type, you can enter the following shortcut codes.

All	[☎] 6 0
Internal	[☎] 6 1 + zone (0 to 6)
External	[☎] 6 2
Combined	[☎] 6 3 + zone (0 to 6)

Activate and deactivate the Page feature

You need to start a Unified Manager session to program this feature. For more information about programming using Unified Manager, see the *Business Communications Manager Programming Operations Guide*.

Create page zones

A zone is any group of telephones that you want to group together for paging, regardless of their location. You can assign one of six zones to each telephone. The maximum number of telephones in a page zone is 50.

You need to start a Unified Manager session to program this feature. For more information about programming using Unified Manager, see the *Business Communications Manager Programming Operations Guide*.

You can make a telephone part of a page zone when the telephone has Page assigned as **Y** (Yes).

Your installer programs the following options:

- a tone sounds before a page announcement begins
- the maximum number of seconds a page announcement can last before it automatically times out



Note: If a telephone has redirect ring enabled, it rings briefly for redirected calls on one of its lines when another telephone has set up the line redirection.

Enter zone: Enter the required page zone number (0- 6) or press ALL.
ALL

Invalid zone You have entered a page zone code that is not between 0 and 6.

Page choice: Select the type of page you want. See the list in [“Make a page announcement” on page 69](#).
SETS SPKR BOTH

Page timeout The time allocated for paging has expired.

Paging ALL You are making a page. The display shows the page zone you have selected. Press or when finished.

Paging busy A page is being made in the page zone you have requested.

For other displays, see [Appendix B, “Common display prompts and error messages,”](#) on page 137.



Note: You can make an announcement to one person by placing a voice call to their telephone.

Using Page with external equipment

When you make a page that uses external paging equipment (external page or combined page), the Long Tones feature automatically activates for the external paging system only. This allows you to control optional equipment with the Long Tones feature.



Messages





The Messages feature allows you to leave a message on the display of another telephone in your system or to analog telephones connected to an Analog Station Module (ASM). The Messages feature indicates if you have any messages waiting.

The Messages feature uses a message waiting list to keep a record of your internal messages and your (external) voice mail messages (if you have access to Business Communications Manager Voice Messaging service with visual message waiting indication).

Send a message

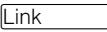
You can leave a message on the display of another telephone in your system. You can send up to four messages to different telephones, including your message center. If your telephone is a direct-dial telephone or a CAP, you can send up to 30 messages.

Only the assigned direct-dial telephone for an analog telephone connected to an ASM can send messages to analog telephones by pressing  . Depending on the programming setup, the analog telephone provides either a Stuttered Dial Tone or a Message Waiting Lamp to tell the user of messages waiting.

For analog telephones connected to an ASM, the message waiting indicator remains on until the user enters    . If the analog telephone has the Message Reply Enhancement feature assigned as Yes, the message waiting indicator turns off automatically after you answer the reply call, no matter where you answer the call. For more information about the Message Reply Enhancement feature, see the *Business Communications Manager Programming Operations Guide*.

To send a message:

- 1 Press **[*]** **[1]**.
- 2 On a telephone with a two-line display, press **ADD**. (This step is not necessary on a telephone with a one-line display.)
- 3 Enter the internal number of the person you want to send the message. The person's display reads **Message for you**.
- 4 On analog telephones connected to an ASM, the message waiting indicator is activated.

Cancel a message you have sent

To cancel a message:

- 1 Press **[*]** **[#]** **[1]**. The display reads **Cancel for:**.
- 2 Enter the internal number of the person you sent the message.

Review your messages

You can receive up to four messages from different telephones, including your message center. A single message from your message center can represent several messages.

On a telephone with a one-line display:

- 1 Press **[*]** **[6]** **[5]**.
The display shows the first message.
- 2 Press **[*]** or **[#]** to move through your messages.

On a telephone with a two-line display:

- 1 Press **MSG**.
The display shows the first message you received.
- 2 Press **NEXT** to move through your messages.

Reply to a message

You can call the person who sent a message, or your message center, while you are viewing the message.

If your reply to a message is forwarded or is answered at another telephone using the Call Pickup feature, the message remains on your telephone until you cancel it or contact the telephone that sent the message.

Press **[0]** to reply to a message on a telephone with a one-line display.

Press **CALL** to reply to a message on a telephone with a two-line display.

If you want to call your message center using a line different from the programmed line, exit your message list and dial the message center telephone number using normal dialing methods.

Reply to a message using an analog telephone connected to an ASM

On an analog telephone connected to an ASM, press **[Link]** * **[6]** **[5]**. The system automatically retrieves and connects the user to the oldest message sender. (The message can originate from either the assigned direct-dial telephone or the internal voice mail system.)

If the analog telephone has the Message Reply Enhancement feature set to Yes, and the sender is the assigned direct-dial telephone, the message waiting indicator turns off automatically after answering the reply call, no matter from where the call is answered.

For analog telephones connected to an ASM, using the Message Waiting Reply feature (**[Link]** * **[6]** **[5]**), retrieves only internal messages sent to the user.

Analog telephones connected to an ASM cannot retrieve external messages by using the Message Waiting Reply feature (**[Link]** * **[6]** **[5]**). For external messages, users must call back the external voice mail center to retrieve their messages. When this happens, the message waiting indicator on the analog telephone is turned off automatically.

If Voice Messaging is not installed on your system, only the assigned direct-dial telephone can send messages to an analog telephone connected to an ASM using **[6]** **[1]**. The analog telephone can in turn enter a single digit access code to reach the assigned direct-dial telephone and retrieve messages.

If the assigned direct-dial telephone of an analog telephone connected to an ASM changes, messages sent by the previous assigned direct-dial telephone remain in the incoming message list of the analog telephone until you retrieve them.

Remove items from your message list

You can erase a message while you are viewing it in your message list. If the message is from your message center, this action only erases the message notification at your telephone. To erase the message at your message center, refer to your message center documentation.

To remove items from your message list on a telephone with a one-line display, press **[Erase]**.

To remove items from your message list on a telephone with a two-line display, press **ERASE**.

Remove items from your message list using an analog telephone connected to an ASM

To remove both internal and external messages on an analog telephone connected to an ASM, press **[Link]** # **[6]** **[5]** to invoke the Cancel Message Waiting feature.

On analog telephones connected to an ASM, the Cancel Message Waiting feature cancels the oldest message received. The system no longer provides either a Stuttered Dial Tone or a Message Waiting Lamp if there are no messages waiting.

View messages you have sent

On a telephone with a two-line display, you can view the messages you have sent.

- 1 Press .
- 2 Press SHOW to view your first sent message.
- 3 Press NEXT to view the rest of your sent messages.

Cancel denied	You have entered an invalid number when trying to cancel a message.
Cleared>LINENAM NEXT	You have cleared an external message from your message waiting list. The message exists in your message center until you erase it there.
In use: 221	You are trying to call from your message waiting list. The line that you are trying to use is in use by the identified user in your system.
L061:LINENAMUMsg NEXT CALL CLEAR	You are viewing your message list. The display shows the number and name of the line used for your message.
Message denied	You have tried to send a message to an invalid internal number or to a telephone that is out of service.
Message list SHOW ADD EXIT	SHOW appears when you have remaining messages. Press <u>SHOW</u> to review messages you have sent. Press <u>ADD</u> to send a new message.
Message to:	Enter the internal number of the telephone to which you want to send a message.
Messages & Calls MSG CALLS	You have one or more messages and one or more new Call Logs. Press <input type="button" value="☎"/> <input type="button" value="8"/> <input type="button" value="0"/> <input type="button" value="6"/> to change the first line of the display to the current time and date.
No button free	You have no line button free with which to reply to a message.
No number stored	There has been no number programmed for the message center. Contact your voice messaging service provider.

Start of list NEXT	You are at the beginning of your list of messages. Press NEXT to move through your messages.
Their list full	You are trying to send a message to a user whose message waiting list is full.
Your list full	You have tried to send a message but your telephone's list of sent messages is full. Cancel one of the messages you have sent, if possible, or wait until you have received a reply to one of those messages.

For other displays, see [Appendix B, "Common display prompts and error messages,"](#) on page 137.

Voice Call

You can make an announcement or begin a conversation through the speaker of another telephone in the system.

Make a Voice Call

To make a Voice Call:

- 1 Press **[☎] [6] [6]**.
- 2 Follow the instructions on the display.

Mute Voice Call tones

When a voice call begins at your telephone, you hear a beep every 15 seconds as a reminder that the microphone is on. To stop the beep, pick up the handset or press the handsfree button.

Answer a Voice Call using Handsfree Answerback

With Handsfree Answerback assigned to your telephone, you can respond to a voice call without touching the telephone.

When a person makes a voice call to you, just start talking. The microphone on the telephone picks up your voice.

After you have answered a voice call, you can put the call on hold, transfer it, or treat the call as a normal call.

Handsfree Answerback is not available to the T7100 telephone.

Voice Call Deny

Press **[☎] [8] [8]** to turn off the Voice Call feature on your telephone.

Voice calls ring like normal internal calls. Your other calls continue normally.

Cancel Voice Call Deny

Press **[☎] [#] [8] [8]** to cancel the Voice Call Deny feature.

Dial voice call Dial the internal number or press the internal autodial button of the person you want to speak to.

Microphone muted Your handsfree microphone is on the mute setting. Press **[☎]** or pickup your handset to respond to the voice call.

No voice call The telephone receiving the call cannot accept voice calls for one of the following reasons: the telephone is active or ringing with another call; Call Forward is on; Do Not Disturb is on; Voice Call Deny is on; it is not a Business Communications Manager telephone.
Your call continues as a normal ringing call.

Voice call The line is open for you to speak.

Chapter 8

Track your incoming calls

You can track information about calls using a Call Log. This chapter shows you a Call Log, and how to use it.

Call Log

If your system has the appropriate equipment and you subscribe to the call information feature supplied by your service provider, you can record information about calls on an external line. The line must appear on that telephone before you can log it, but it does not have to be a ringing line. ISDN service packages that come with calling line identification (CLID) can supply the same feature.

Call Log creates a record of incoming external calls. For each call, the log can contain:

- sequence number in the Call Log
- name and number of the caller
- indication if the call was long distance
- indication if the call was answered and by whom
- time and date of the call
- number of repeated calls from the same source
- name of the line on which the call came

Call Log can help you to

- keep track of discarded calls or calls not answered
- track patterns for your callers (for example volume of calls and geographic area of calls)
- record caller information quickly and accurately
- build a personal telephone directory from log items

Information such as long distance indicator and the caller's name and number, may not show in the log. The appearance depends on the Call Display services provided by your local telephone company and the caller's local telephone company.

To use the features on the following pages, your telephone must have spaces available in its Call Log. Your installer programs each telephone with an appropriate number of spaces.

Call Log options

You can select the type of calls to store in your Call Log. Select from four Autolog options: **No one answered**, **Unanswered by me**, **Log all calls**, **No autologging**.

To use Call Log:

- 1 Press **[☎] [*] [8] [4]**. The display shows the current option.
- 2 Press **[#]** or **NEXT** to change the option.
- 3 Press **[☺]** or **OK** to select the display option.

Log a call manually

If your calls are not automatically logged, you can manually log call information when connected to an external call. You can store information for your current call for future reference. For example, you can:

- record a caller's information without using paper and pencil
- record only selected calls as opposed to logging all calls
- quickly record call information before a caller hangs up

Press **[☎] [8] [1] [3]** to log an external call manually.

Delete old log items

Your log has a set number of items that it can hold. When the log is full, you can no longer log new calls. When your log is full, the Autobumping function automatically deletes the oldest Call Log item when a new call is logged.

Press **[☎] [8] [1] [5]** to enable autobumping.

Press **[☎] [#] [8] [1] [5]** to disable autobumping.

View your Call Log

To view your log:

- 1 Press **[☎] [8] [1] [2]**. The display shows the number of previously read items (old) and the number of new items in the log.
- 2 Press **[*]** or **OLD** to view old items; press **[#]** or **NEW** to view new items.
- 3 Press **[0]** or **RESUME** to display the last item you viewed, the last time you accessed your Call Log.



When you subscribe to Call Display services from your local telephone company, names and numbers for external callers appear on the display.

View a Call Log item



Press **[◀] [▶]** or **MORE** to view the information for a call log item.

Erase log items

You must erase log items that you have read, to make space for new items in your log.

- 1 Display the item you want to erase.
- 2 Press  or **ERASE**.
- 3 Press  to exit.



If you accidentally erase an item, you can retrieve the item.

- 1 Press  or **UNDO** after accidentally erasing an item.
- 2 Press  to exit.

Make a call using Call Log

You can place calls from within your Call Log. The number stored for a call can vary depending on the type of call. For example, if the call came from a Centrex or PBX system, you can trim the first few numbers before you make the call. If the number you want to call is long distance, or if you want to use a line pool, you may need to add numbers.

To place a call:

- 1 Display the log item for the call you want to place.
- 2 Display the related telephone number.
- 3 Press   or **TRIM**, one time for every digit that you want to remove.
- 4 Dial any additional digits required.
- 5 Press an external line or line pool button.
- 6 Lift the handset or press Handsfree.

Create a password to your Call Log

To access your Call Log through a password:

- 1 Press  * 8 5 . The display shows **New Password:**.
- 2 Enter your four-digit password. The display shows **Repeat New:**.
- 3 Re-enter your four-digit password. The display shows **Password changed**, to confirm the change.

To enter Call Log using a password:

- 1 Press  8 1 2 to enter Call Log. If you have programmed a password, the display shows **Password:**.
- 2 Enter your four-digit password.

If you do not remember your Call Log password, programming from Unified Manager can delete the password. For more information about programming using Unified Manager, see the *Business Communications Manager Programming Operations Guide*.

Change your Call Log password

- 1 Press **[Clear] [*] [8] [5]**. The display shows **Old Password:**.
- 2 Enter your old password. The display shows **New Password:**.
- 3 Enter your new four-digit password. The display shows **Repeat New:**.
- 4 Re-enter your password. The display shows **Password changed** to confirm the change.

Delete an assigned password

- 1 Press **[Clear] [*] [8] [5]**. The display shows **Old Password:**.
- 2 Enter your old password. The display shows **New Password:**.
- 3 Press **[Back]** or **OK**. The display shows **No Pswd assigned**, to confirm the change.

Program a telephone to log calls automatically

Your installer can program each telephone to automatically log calls coming in on a line.

1:Unknown name The caller's name is not available.

1:Unknown number The caller's number is not available.

12:KATE SMITH _ indicates a new item.
NEXT ERASE MORE

12:KATE SMITH Ⓜ indicates that the call was answered.
NEXT ERASE MORE

12SKATE SMITH Ⓢ indicates a long distance call.
NEXT ERASE MORE

49/1234567890123 / indicates the stored number was trimmed to its final 11 digits.
NEXT ERASE MORE Press **[Left] [] [Right]** or **MORE** to show additional information about the call.

Call(s) bumped One or more log entries are deleted by the Autobumping feature while you are viewing at the Call Log.

<code>Hold or release</code>	Hold or release your active call before entering Call Log.
<code>In use: SETNAME</code>	The external line is in use.
<code>Jan 4 9:00a 3X</code> <code>NEXT ERASE MORE</code>	The repeat call counter, shown with time and date, indicates the number of calls you have received from the same caller.
<code>Line061 227</code> <code>NEXT ERASE MORE</code>	This call was answered at another telephone (227).
<code>Line061 Logit</code> <code>NEXT ERASE MORE</code>	This call was logged manually.
<code>Line061</code> <code>NEXT ERASE MORE</code>	This call was not answered.
<code>Messages & Calls</code> <code>MSG CALLS</code>	There are one or more items in your message waiting list, and there are one or more new items in your Call Log. Press <code>[e] [8] [0] [6]</code> to change the first line of the display to the current time and date.
<code>New calls begin</code>	You have viewed your last old log item and now you can view your new log items.
<code>No info to log</code>	No information is available for the call.
<code>No log assigned</code>	No log space has been assigned to the telephone.
<code>No resume item</code>	The resume item has been removed because of Autobumping, repeat call update, or log reallocation while you are looking at the Call Log.

For other displays, see [Appendix B, “Common display prompts and error messages,”](#) on page 137.

Chapter 9

Customize your telephone

You can customize your telephone to suit your needs. You can check the functions of buttons using button inquiry. You can also:

- change the contrast of display
- change the language
- adjust the ring type and volume
- change button assignment

Adjust the contrast on the display

- 1 Press **[☎] [*] [7]**.
- 2 Press a number on the dial pad to select the contrast level you prefer.
- 3 Press **[☺]** to save your setting.

On a two-line telephone, you can use the **UP** and **DOWN** display buttons to adjust the contrast. The number of contrast levels available varies from one telephone model to another.

Change the language on the display

You can select the language that appears on the display of each telephone. System software supports four language options: Primary, Alternate, Alternate 2, and Alternate 3. All telephones default to the Primary language at installation. Table 4 shows the different language options available to each telephone. See [“Language options” on page 83](#).

Table 4 Language options

Language feature code	Language
[☎] [*] [5] [0] [1]	Language - Primary
[☎] [*] [5] [0] [2]	Language - Alternate
[☎] [*] [5] [0] [3]	Language - Alternate 2
[☎] [*] [5] [0] [4]	Language - Alternate 3

If you program **[☎] [*] [5] [0] [1]** to a memory button, you can press that button until the language you want appears on the display. You cannot program **[☎] [*] [5] [0] [2]**, **[☎] [*] [5] [0] [3]** or **[☎] [*] [5] [0] [4]** to a memory button.

Change the type of ring

You can select one of four different rings for your telephone. This selection makes it easier to identify your telephone in an open office.

- 1 Press **[☎] [*] [6]**.
- 2 Press **[1]**, **[2]**, **[3]**, **[4]**, or **NEXT**.
You hear the selected ring for two seconds.
- 3 Repeat until you hear the ring you like, then press **[☎]** or **OK**.

Adjust the Ring volume

- 1 Press **[☎] [*] [8] [0]**.
The telephone rings.
- 2 Press **[←] [→]** to adjust the volume: left end to decrease, and right end to increase.

Button Inquiry

You can check the function of any line, intercom, or programmed button on your Business Communications Manager telephone by pressing **[☎] [*] [0]** and a button. On the T7100 telephone, Button Inquiry shows your internal number followed by the function assigned to your single memory button.

061 <LINENAME>
SHOW OK

The display shows the number and name of the line. Press **SHOW** to view the redirection status of the line.

123456789012345...
VIEW→OK

Press **#** or press **VIEW→** or **←VIEW** to view a number that is too long to fit on the display. Press **[☎]** or **OK** when done.

221 <SETNAME>
NEXT VIEW→

The display shows the directory number of the telephone, and the assigned name. Press **NEXT** to see the first line assigned to ring at the intercom button.

<Feature name>
SHOW OK

The name of the feature assigned to a button appears on the display when you press the button. Press **#** or **SHOW** for additional information.

Press a button
EXIT

Press the button you want to check. Press **[☎]** or **EXIT** when finished.

For other displays, see [Appendix B, “Common display prompts and error messages,”](#) on page 137.

Programming feature codes

You can program a feature code to a memory button.

Any memory button not programmed as an external or internal line, target line, Answer button, or Handsfree/Mute button, is available for features.

- 1 Press .
- 2 Press the memory button you want to program with a feature.
- 3 Enter the appropriate feature code you want to assign to the button.

You cannot program the following feature codes on a memory button: Long Tones and any code beginning with except (Language Option) and (Contrast Adjustment).



Note: When you program a button with the line pool feature code, you must enter a line pool access code after the feature code. The programmed line pool button accesses a specific line pool, not the line pool feature.

Erase a feature button

- 1 Press .
- 2 Press the feature button.
- 3 Press or OK to erase the button.

<Feature name>
SHOW OK

The name of the feature assigned to a button appears on the display when you press the button. SHOW appears when there is more information available. Press or SHOW for additional information.

Enter code:

If you are checking a speed dial button, enter the two-digit speed dial code that you want to check.

F_
QUIT CLEAR





Enter the feature code, or press or QUIT to end programming or CLEAR to clear the numbers entered. The system accepts the entry when you enter a valid feature code.

Feature code:
QUIT

Press and enter the feature code you want to assign to the button. Check that the code is valid.

Feature moved

You have programmed a button with a feature programmed on another button. The feature has moved to the button you just programmed. The original button is now blank.

Press a button EXIT	Press the button you want to check. Press  or EXIT when finished.
Program and HOLD	Enter the number you want to program and press  . To erase the button, press  .
Program and OK QUIT OK	Enter the number you want to program and press OK . To erase the button, just press  or OK .

For other displays, see [Appendix B, “Common display prompts and error messages,”](#) on page 137.

Default button assignments

During Startup, the installer chooses one of the available templates. Default features are assigned automatically to the programmable buttons on telephones in the system, and vary with the template and the telephone. The default features appear in the following tables in this chapter.

Rules of default button assignment

Line and Intercom buttons assigned by default templates can be changed in programming. Handsfree/Mute and answer button features are not assigned by default. If these features are defined, however, they are automatically assigned to specific buttons, as described on this and the following page. None of these buttons are available on the T7100 telephones. Refer to [“T7316 and T7208 telephone button defaults”](#) on page 88.

The T7316 and T7208 telephones can have up to eight Intercom buttons. They appear above the Handsfree button at the bottom right-hand corner on your telephone.

Each telephone can have up to four answer buttons. They appear above Intercom buttons in the right column and continue up from the bottom in the left column, replacing the features on those buttons.

External line buttons appear in ascending line order, starting at the top button in the left column (the top button on the T7208 telephone). If more than eight external lines are assigned to a T7316 telephone, or more than 12 to a M7324(N) telephone, assignment continues down the buttons on the right column, erasing the feature codes on those buttons. Line buttons have priority over feature access buttons except for the Handsfree, Intercom, or answer buttons.

T7316 Button mapping

Button mapping for the T7316 telephone is unique because this telephone has more buttons than the other telephone types. Internal autodial numbers are assigned to buttons, 11, 13, 15, 17, 19, and 21. Programmed external line buttons appear in descending line order starting with button 1. When more than five external lines are programmed, assignment continues on button 6 and continues in descending order.

Programmed intercom buttons appear on buttons 9 and 10. When you require more than two intercom buttons, you can use button 8. When the Handsfree feature is programmed to your telephone, the feature appears on button 10, moving intercom button(s) up one position.

Programmed telephone features are assigned to the remaining available buttons. Default internal autodial numbers are assigned to the eight programmable buttons at the top of your T7316 telephone. Figure 7 shows the button number assignments on the T7316 telephone. See [“Button assignment on the T7316 telephone” on page 87](#).

Figure 7 Button assignment on the T7316 telephone

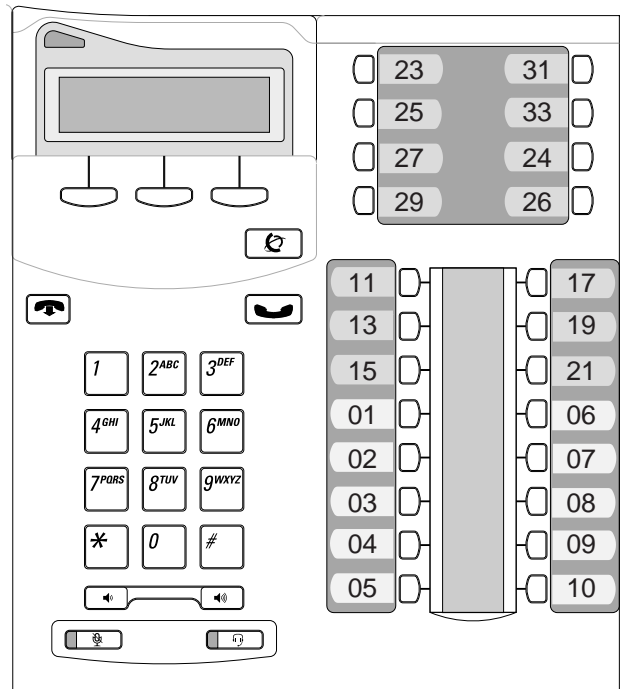

T7316 and T7208 telephone button defaults

The default button assignments for the T7316 and T7208 telephones depend on the template applied. Table 5 shows the button assignment template for the T7316 telephone. See [“T7316 button assignment template” on page 88](#). Refer also to [“Telephone buttons” on page 25](#).

Table 5 T7316 button assignment template

PBX	Button Number	DID
DND	01	Line
Transfer	02	Transfer
Call Forward	03	Call Forward
Pick-Up	04	Pick-Up
Page-General	05	Page-General
Conference	06	Conference
Last No. Redial	07	Last No. Redial
Intercom	08	Intercom
Intercom	09	Intercom
Handsfree/Mute	10	Handsfree/Mute

Table 6 shows the button assignment template for the T7208 telephone. See [“T7208 button assignment template” on page 88](#).

Table 6 T7208 button assignment template

PBX	Button Numbers	DID
Pick-Up	01	Line
Transfer	02	Transfer
Last No. Redial	03	Last No. Redial
Page-General	04	Page-General
Conference	05	Conference
Intercom	06	Intercom
Intercom	07	Intercom
Handsfree/Mute	08	Handsfree/Mute

M7324 Button mapping

Button mapping for the M7324 telephone is unique because this telephone has a different layout and more buttons than the other telephone types. Programmed external line buttons appear in descending line order starting with button 1.

Programmed intercom buttons appear on buttons 23 and 24. When you require more than two intercom buttons, you can use button 22. When the Handsfree feature is programmed to your telephone, the feature appears on button 24, moving intercom button(s) up one position.

Programmed telephone features are assigned to the remaining available buttons. Figure 8 shows the button number assignments on the M7324 telephone. See [“Button assignment on the M7324 telephone” on page 89](#).

Figure 8 Button assignment on the M7324 telephone

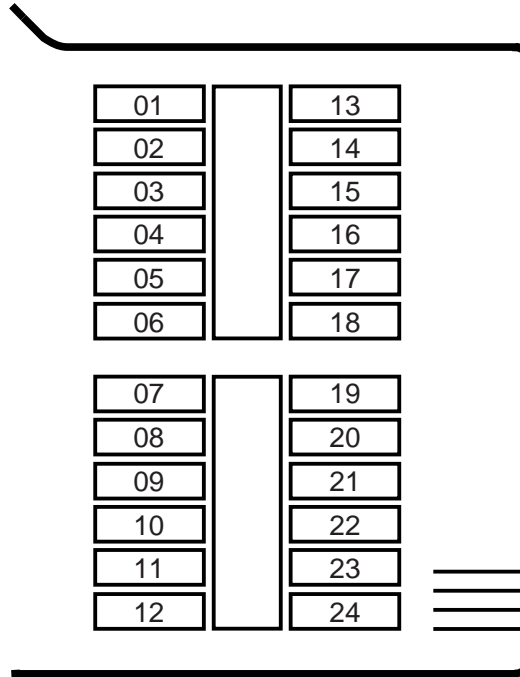

M7324(N) telephone button defaults

The default button assignments for the M7324(N) telephone depend on the template applied. Table 7 shows the button assignment template for the M7324(N) telephone. See [“M7324\(N\) button assignment template” on page 89](#). Refer also to [“Telephone buttons” on page 25](#).

Table 7 M7324(N) button assignment template

PBX	Button number	DID
<input type="text"/>	01	Line <xx>
<input type="text"/>	02	Transfer
<input type="text"/>	03	<input type="text"/>
<input type="text"/>	04	<input type="text"/>
<input type="text"/>	05	<input type="text"/>
<input type="text"/>	06	<input type="text"/>
<input type="text"/>	07	<input type="text"/>
<input type="text"/>	08	<input type="text"/>
<input type="text"/>	09	<input type="text"/>
<input type="text"/>	10	<input type="text"/>

<input type="text"/>	11	<input type="text"/>
<input type="text"/>	12	<input type="text"/>
Call Fwd.	13	Call Fwd.
Speed Dial	14	Speed Dial
Last No.	15	Last No.
Saved No.	16	Saved No.
Conf/Trans	17	Conf/Trans
Transfer	18	Transfer
DND	19	DND
Pick-Up	20	Pick-Up
Voice Call	21	Voice Call
Page	22	Page
Intercom	23	Intercom
Intercom	24	Intercom

T7100 telephone button defaults

For all templates assigned to the T7100, the one programmable button on the T7100 telephone is

Last No.



Note: The default Page button activates the External Page option (6 2).

Move line buttons

You can move external lines to different buttons on your telephone.

- 1 Press * 8 1.
- 2 Press the line button you want to move.
- 3 Press the button to which you want to move the line.
- 4 Press .

You cannot move intercom, answer or Handsfree/Mute buttons on a CAP module.

Exchanged

The two buttons you selected have exchanged position.

Invalid location

You tried to move a line to a button that cannot be a line button, such as an intercom button, Handsfree/Mute button, or an answer button.

- Move line from:** **QUIT** Press the button of the line you want to move. Press **☐** or **QUIT** when you have finished moving lines.
- Move line to:** **QUIT** Press the button you want to move the line to. Neither of the buttons is erased. The lines, or the line and feature, switch places.
- Press a line** The button you are trying to move is not a line button. If you are trying to switch a line and a feature, move the line to the feature button and not the feature button to the line.

Hide the message or calls indication

The display that shows you have messages or calls can be replaced with the current time and date.

If you are using a telephone with a one-line display, the message or call indication is hidden.

- 1 Press **☐** **8** **0** **6** .
The current time and date appears on the first line of the display.
- 2 Press **MSG** or **☐** **6** **5** to see your messages, or press **CALLS** or **☐** **8** **1** **2** to see your calls.

Restore the messages and calls indication

You can retrieve your message and call information by using the display buttons that appear on the second line of the display.

Press **☐** **#** **8** **0** **6** to retrieve a message and call information.

Chapter 10

Hunt Groups

The Hunt Groups feature allows access to a group of Business Communications Manager telephones by entering a single extension number. This ensures that calls easily route to the appropriate group.

Hunt Groups are used in conditions where a group of people performing the same task answer a number of related telephone queries. Some typical uses of Hunt Groups are:

- a sales department answering questions on product prices or availability
- a support department answering questions describing the operation of a product
- an emergency department answering calls for help

As an example, consider Hunt Groups that route calls to a support service such as a help line for a software company. Specialists handling Product A can be in one group, and specialists handling Product B can be in another group. Incoming calls hunt for the next available telephone in the group. If no telephone is available, the call is placed in a queue or is routed to an overflow telephone.

You need to start a Unified Manager session to program this feature. For more information about programming using Unified Manager, see the *Business Communications Manager Programming Operations Guide*.

You can make programming changes to the following Hunt Group settings:

- members of a group and member position in a group
- line assigned to a group
- distribution of incoming calls
- how long the system looks for available members
- where a call goes if all members are busy

Features affected by Hunt Groups include:

- Call Forward All Calls
- Call Forward No Answer
- Call Forward on Busy
- Group Pickup
- Transfer via Hold
- Priority Call
- Line Redirection
- Page Zones
- Voice Call

Members of the group

Members of the group can be any telephones in the system or portable telephones. Each telephone can be in more than one Hunt Group, and considered a member in each Hunt Group, increasing the total number of members in the system.

There is only one appearance of the same Hunt Group on a set. Hunt Group extension numbers cannot be members of other Hunt Groups. An extension number can be related with a member of a Hunt Group and is called a member extension number.

Distribution mode

There are three modes of call distribution:

- **Broadcast**—rings every set in the group at the same time. Calls are handled one at a time; other calls are put in a queue. When a call is picked up, the call next in the queue is shown to the Hunt Group without having to wait for queue time-out.

In Broadcast mode you can program all the attendants in the group to share the load of answering large volumes of calls. All sets automatically display the calling line identification (CLID), if available. A known example is a fund raising campaign where a group of operators are waiting to take each call as it comes in.

- **Sequential**—starts the call at the first set in the Hunt Group and distribution is complete when the first free set is found. Simultaneous calls can be shown. Distribution is order based.

In Sequential mode, you can program your top salesperson to be the first member of the group to receive incoming calls.

- **Rotary (Cyclic)**—the call starts at the set after the one which answered the last call. Distribution is complete when the next free set is found. Simultaneous calls can be shown. Distribution is order based.

In Rotary (Cyclic) mode, you can ensure that all your help line people receive calls on an equal basis, instead of one person receiving most of the calls. The call rings at one set at a time in a rotation.

If a Hunt Group has available members but no one answers the call, the call routes through the Hunt Group list until either a person answers the call or the queue time-out occurs. In the second case, the call routes to the overflow position. After a call goes to the overflow position it is no longer a Hunt Group call.

For information about Hunt Groups, see the *Business Communications Manager Programming Operations Guide*.

Chapter 11

Telephone features

This chapter shows you how to:

- move a telephone
- prevent a call from ringing at a telephone
- turn Privacy on and off
- use the Handsfree and Mute features
- time a call
- recover from an accidental disconnect
- play music in the background

Moving telephones



Caution: You can be required by law to report any telephone moves to your local telecommunications carrier or 911 service provider. For more details, ask your local carrier, your local 911 service provider, and/or your local telecommunications service provider.

When automatic telephone relocation is enabled in programming by your installer, you can move your telephone from one jack to another without losing any of its custom programming.

Hunt Groups

Business Communications Manager allows you to establish Hunt Groups in your system. A Hunt Groups is a group of telephones that is accessible by entering a extension number. The Hunt Groups feature ensures calls route to the appropriate people. For more information about Hunt Groups see [Chapter 10, “Hunt Groups,” on page 93](#).

Prevent calls from ringing at your telephone



You can prevent calls from ringing at your telephone, either when you are away from your desk or while on another call with the Do Not Disturb (DND) feature.

Use Do Not Disturb

After you turn Do Not Disturb on, calls are forwarded to the prime telephone when there is no other telephone on which the line appears. If there is another telephone that shares the same line, the call can be answered by that person. (The Delayed Ring Transfer feature transfers all calls not answered, to the prime telephone after a defined time.)



Do Not Disturb prevents voice calls from alerting at your telephone. Voice calls appear as normal intercom calls.

Cancel Do Not Disturb

Press  #   to cancel Do not Disturb.

 Your telephone receives calls normally.



Stop calls

Press    to stop calls from ringing at your telephone.

You only receive priority calls at your telephone. A line button flashes when you receive a call, but the call does not ring.

Refuse to answer a call

If your telephone rings while you are on a call, you can refuse to answer the second call, even if it is a priority call.

To refuse a call, press    while your telephone is ringing.

Turn Privacy on or off for a call

You can configure lines in your system to have automatic privacy. With a line not programmed with privacy, anyone with the line assigned to their telephone can join your call by pressing the line button. With a line programmed with privacy, one person at a time can use the line.

Privacy control cannot be for internal or conference calls.



When another telephone joins a call, the participants on the call hear a tone, and a message appears on the telephone display. It is not possible to join a call without everyone hearing this tone.



Note: The Privacy feature does not apply to target line calls.

Create a conference call by releasing privacy



With a line programmed with privacy, you can turn privacy off to allow another person with the same line to join in your conversation and form a conference. All the rules for a conference apply but there is one line in use, instead of the normal two. This means that you cannot split a conference set up using Privacy.

- 1 Press   .
- 2 Tell the other person to press the line button and join your conversation.

Only two Business Communications Manager telephones and the external caller can take part in this kind of conference.

Make a call private

With a line programmed not to have privacy, you can turn privacy on for a call, preventing other people with the same line from joining.

Press    to make a private call.

Handsfree and Mute

You must assign the ability to use Handsfree to on or off for each telephone. Also program the type of Handsfree. See [“Change Handsfree for a telephone” on page 98](#). You must also turn on Handsfree for a telephone to use a headset.

Answer calls without lifting the handset

- 1 Press the line button for the ringing call.
- 2 Press the handsfree button. The telephone’s internal microphone and speaker automatically turn on.

Handsfree is not available for a T7100 telephone.



Note: Direct your voice toward the telephone. The nearer you are to the telephone, the easier it is for the microphone to transmit your voice to your listener.

Make calls without lifting the handset

- 1 Press the handsfree button. The telephone’s internal microphone and speaker automatically turn on.
- 2 Dial your call.
- 3 Speak normally.

Mute Handsfree

- 1 Press  to switch off the telephone microphone so that you can speak to a person in your office while you are on a handsfree call. The display reads Microphone Muted.
- 2 Press the handsfree button to turn the microphone back on again and continue your handsfree call.

Change a normal call to handsfree

- 1 Press the handsfree button.
- 2 Hang up the handset.

Change a handsfree call to a normal call

To switch from handsfree, lift the handset.

Handsfree

The indicator next to the handsfree button is solid when you have Handsfree turned on. It flashes when you mute the microphone.

Wait for your caller to finish speaking before you speak. The microphone and speaker cannot both be on at the same time. Your caller's voice can be cut off if you both speak at the same time. Interruptions such as a tapping pencil can be loud enough to turn on your microphone and cut off your caller's speech.

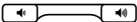
To prevent an echo, keep the area around your telephone free of paper and other objects that can screen your microphone. Turn down the microphone's volume (press the left end of ) while speaking) to prevent feedback. When you change the volume level, both the microphone and speaker volume adjust to prevent feedback problems.

Position the telephone so that any unavoidable local noise (such as an air conditioner) is behind it. This position limits the amount of background noise.



Note: In open office environments, use the handset when handsfree communication is not necessary or when you need privacy during a call. Another option is to use a headset.

Change Handsfree for a telephone

You can program the type of Handsfree used with each telephone or activate Handsfree Answerback.

You need to start a Unified Manager session to program this feature. For more information about programming using Unified Manager, see the *Business Communications Manager Programming Operations Guide*.

Handsfree Answerback

Handsfree Answerback allows you to answer a voice call without lifting the handset. Handsfree Answerback is always turned off for a T7100 telephone.

You can turn Handsfree Answerback on or off for a telephone programmed to use Handsfree. You need to start a Unified Manager session to program this feature. For more information about programming using Unified Manager, see the *Business Communications Manager Programming Operations Guide*.

Hearing aid compatibility

The handsets on all system telephones are compatible with hearing aids as defined in the FCC rules, Part 68, section 68.316. Not all hearing aids are optimized for use with a telephone.

Call Duration Timer

Press **[*] [7] [7]** to see how long you were on your last call, or how long you have been on your current call.

221 02:47 The display shows the last call you made, or the current call, and the total elapsed time in minutes and seconds.

Line061 01:45 You parked your last call. You cannot see the length of time a call was parked.

Accidental disconnect

If you accidentally drop the handset back into the telephone cradle while answering a call, you can retrieve the call.

Pick up the handset again or press the handsfree button within one second to reconnect to your call.

Disconnect supervision

When disconnect supervision is assigned to a line, the system detects when an external caller hangs up and releases the line for other uses. The installer assigns disconnect supervision.

Time

Press **[*] [8] [0] [3]** to display the current date and time while you are on a call.

Press **[*] 8 0 6** to display the static time.

Press **[*] # 8 0 6** to cancel the static time feature.

Background Music

Press **[*] 8 6** to listen to music through your telephone speaker.

Your installer makes this feature available to all telephones in programming. You need to supply a music source, such as a radio, which is attached to your system.



Warning: According to U.S. copyright law, a license can be required from the American Society of Composers, Authors and Publishers or a similar organization if radio or TV broadcasts are transmitted through the Background Music feature of this telecommunication system.

Nortel Networks hereby disclaims any liability occurring as a result of failure to get a license.

Cancel Background Music

Press **[*] # 8 6**. The music stops automatically if you make or answer a call.

Chapter 12

System features

This chapter describes how Business Communications Manager sends and receives different types of information. This chapter also shows you a variety of services and how to use them.

ISDN

Integrated Services Digital Network (ISDN) technology provides a fast, accurate and reliable means of sending and receiving data, image text and voice information through the telephone system.

Using ISDN Primary Rate Interface (PRI) or Basic Rate Interface (BRI) allows for faster transmission speeds and the addition of many powerful business applications, including remote LAN access, video conferencing, file transfer, and Internet access.

Your installer or service representative configures your ISDN services and telephone equipment. For more information about ISDN, see the *Business Communications Manager Programming Operations Guide*.

You can use selected ISDN network features from a telephone in the system. Your central office switch (ISDN network) determines which features are available to you.

Network name display

Your system shows the name of an incoming call when it is available from the service provider. Name information appears on the display of a telephone. If the Calling Party Name has the status of “private” it appears on the display as “Private name.” If the Calling Party Name is not available it can appear on the display as “Unknown name.”

Your telephone display shows the name of the called party on an outgoing call, when available from your service provider.

Your system sends the Business Name concatenated with the set name on an outgoing call but only after the Business Name is programmed.

Name and number blocking

When activated, allows you to block the outgoing name and/or number on a per-call basis. All telephones in the system can use the Name and number blocking feature.

Ask your customer service representative if this feature is compatible with the features available from your service provider.

Use alternate or scheduled services

There are three types of services for Business Communications Manager to handle calls in a different way on different days, and at different times of the day:

- Restriction service
- Ringing service
- Routing service

The installer customizes and programs all three services, that is the six schedules available to each service. The installer programs one telephone used to turn services on and off, and display what services are in use. This specific telephone is called the control telephone.

Restriction service

Restriction service prevents a user from dialing some types of calls from a telephone or from lines that are available at the telephone. The installer programs restrictions.

Ringing service

Ringing service makes additional telephones ring for incoming calls on external lines. For example, incoming external calls can ring at a security guard's telephone during the night, or calls to one attendant can ring at another attendant's telephone during lunch. Ringing service does not suppress your normal ringing assignment.

Routing service

Routing service allows you to assign alternate routes to calls. You can take advantage of lower costs available on selected routes for some days and at some times. Both the normal and alternate routes are programmed by your installer.

Turning services on and off

Three programming settings: Manual, Automatic and Off, control how the system uses different services and their schedules.







- Manual allows you to turn the service on and off at any time from a control telephone using a feature code.
- Automatic allows you to use the pre-assigned stop and start time for a service. You can enable and cancel the service by entering the appropriate feature code at a control telephone. If you select this setting, you use the start and stop times programmed by your installer.
- Off prevents the service from being activated.

For more information about programming using Unified Manager, see the *Business Communications Manager Programming Operations Guide*.

Each schedule can have its configuration of a service which works separately from automatic start and stop times. For example, in Restriction service, the Night schedule prevents people from making long distance calls. Calling the restriction Night schedule does not limit the use to that specific schedule. You can turn the Night schedule for Restriction service on or off as needed any time of the day or night. If you decide to run a service on a schedule, the system uses the start and stop times used for the schedule you set up.

Turn services on and off using feature codes

You can access the master control for services through the Unified Manager. The following feature codes allow access and control of the day-to-day use of services.

 8 7 1	Turns on Ringing service. When used at the direct dial telephone, it activates the alternate direct dial telephone (extra dial telephone).
 # 8 7 1	Turns off Ringing service.
 8 7 2	Turns on Restriction service.
 # 8 7 2	Turns off Restriction service.
 8 7 3	Turns on Routing service.
 # 8 7 3	Turns off Routing service.

To turn a service on:

- 1 Enter the appropriate feature code from a control telephone.
- 2 Press **NEXT** to move through the schedules until the display shows the version of the service you want turned on.
- 3 Press **OK** to select the setting, or press **QUIT** to exit the feature without making any changes.

To turn a service off, enter the appropriate feature code from a control telephone.



Caution: Assigning a service as Normal is not the same as canceling a service using a feature code. If you assign the service as Normal, the normal version of a service overrides any automatic schedule and remains until you manually cancel it. When you cancel service by feature code, you return to the automatic schedule.

View active services from a two-line display telephone

When a service is active, the control telephone display shows **Services ON**.

- 1 Press **LIST**. The display shows the first active service and the schedule in use.
- 2 If there are several active services, press **NEXT** to view all of the services.
- 3 Press **EXIT** to exit the feature.

View active services from a one-line display telephone

- 1 Press **[*] [8] [7] [0]**. The display shows the first active service.
- 2 Press **[#]** to move through the active schedule.
- 3 Press **[*]** to exit.

<Sched> Restr'n
EXIT NEXT

You are viewing the active services. Press **[#]** or **NEXT** to view the other active services. Press **[*]** or **EXIT** to quit.

<Sched> Restr'n
QUIT OK NEXT

The name of the current Restriction service schedule appears on the display. Press **[#]** or **NEXT** to view the other Ringing service schedules. Press **[*]** or **OK** to select the required schedule.

<Sched> Ringing
EXIT NEXT

You are viewing the active services. Press **[#]** or **NEXT** to view the other active services. Press **[*]** or **EXIT** to quit.

<Sched> Ringing
QUIT OK NEXT

The name of the current ringing service schedule appears on the display. Press **[#]** or **NEXT** to view the other Ringing service schedules. Press **[*]** or **OK** to select the required schedule.

<Sched> Routing
EXIT NEXT

You are viewing the active services. Press **[#]** or **NEXT** to view the other active services. Press **[*]** or **EXIT** to quit.

<Sched> Routing
QUIT OK NEXT

The name of the current Routing service schedule appears on the display. Press **[#]** or **NEXT** to view the other Routing service schedules. Press **[*]** or **OK** to select the required schedule.

<Sched> until *
QUIT OK NEXT

Press **[*]** or **OK** to select this schedule, **[#]** or **NEXT** to view the next available schedule, or **[*]** or **QUIT** to exit. If you select this schedule, it remains active until the next automatic schedule begins.

No services ON

You have entered the Show services feature code and there is no active service.

Services ON
LIST

There is a service active in your system. Press **[*]** or **LIST** to view the active services.

For other displays, see [Appendix B, "Common display prompts and error messages,"](#) on page 137.

Services that turn on automatically have an asterisk (*) appearing before the name on the display. You can not manually activate or cancel scheduled services. However, you can override a schedule service by manually activating another schedule.

The control telephone can override services turned on and off according to a schedule by entering a Services feature code, and selecting a different schedule. This override remains until canceled. If you select a schedule with an asterisk (*), the next automatic service schedule comes into effect at the programmed time.

Direct-dial calls to a direct-dial telephone ring at the extra dial telephone when you enter the Ringing service feature code (☎ 8 7 1) at that direct dial telephone. The installer assigns the extra dial telephone. Note that only the extra dial telephone is activated, not the actual Ringing service (unless that direct-dial telephone is a control telephone).



Note: The system provides six service schedules: Night, Lunch, Evening, Sched 4, Sched 5, and Sched 6. Your installer can change these names to meet your business requirements.

User passwords

User passwords prevent unauthorized or accidental changes to your system. There are two types of user password: Registration and Call Log.

Registration password

The Registration password controls the registration of companion portables to the Business Communications Manager system. For more information see the *Business Communications Manager Programming Operations Guide*.

Log password

If a person does not remember their Call Log password, you can clear the previously assigned password in programming. The person can enter a new password from their telephone.

You need to start a Unified Manager session to program this feature. For more information about programming using Unified Manager, see the *Business Communications Manager Programming Operations Guide*.

Special telephones

You can dedicate telephones to serve special functions such as:

- Direct dial
- Hotline
- Control

Direct dial

You can reach the direct dial telephone by dialing a single digit. The direct dial telephone is normally in a central location, such as an attendant's desk. You can have up to five direct dial telephones for your system. The direct dial telephone is normally the prime telephone or the central answering position (CAP).

The direct dial telephone can send up to 30 messages and can activate services to activate the extra dial telephone.

Change direct dial telephone assignments

Your installer assigns the direct dial telephone during installation.

You can change the direct dial telephone. You need to start a Unified Manager session to program this feature. For more information about programming using Unified Manager, see the *Business Communications Manager Programming Operations Guide*.

You can assign any number of telephones to call the direct dial telephone.

Hotline

A hotline telephone calls a set internal or external telephone number when you pick up the handset or press the handsfree button.



Note: Label the hotline telephone to warn anyone using it that it is active.

Hotline bypass

Press a line button, or use the Pre-Dial or Automatic Dial feature before you pick up the handset or press the handsfree button on a hotline telephone. See the *Telephone Feature Card* or see [“Select how you dial your calls” on page 42](#).

Make a telephone a hotline telephone

You can set up a telephone as a hotline.

You need to start a Unified Manager session to program this feature. For more information about programming using Unified Manager, see the *Business Communications Manager Programming Operations Guide*.

The Internal option assigns an internal number. The External option assigns an external number. If you select an external number, you can select the line on which the call is made: the prime line, an external line, a line in a line pool, or a line selected by the routing table. If you select a line pool, you must indicate the line pool access code. If you select the routing table, the number dialed is considered as a destination code and routes according to the routing tables.

The installer programs a telephone’s prime line, line pool access codes, and access to a line pool.

Control telephone

The control telephone allows you to place the telephones and external lines for which it is responsible into and out of service schedules. See [“Use alternate or scheduled services” on page 102](#).

Set lock

Set lock limits your ability to customize a telephone. There are three levels of Set Lock:

- Partial
- Full
- None

None allows you to access all features on your telephone.

Partial prevents:

- programming autodial buttons
- programming the user speed dial numbers
- programming feature buttons
- moving line buttons
- changing the display language
- changing dialing modes (Automatic Dial, Pre-Dial, and Standard Dial)
- using Voice Call Deny
- saving a number with Saved Number Redial

Full, with the restrictions described for Partial lock, prevents:

- changing Background Music
- changing Privacy
- changing Do Not Disturb
- using Ring Again
- using Call Forward all calls
- using Send Message
- using Trunk Answer
- activating Services

Change Set Lock programming for a telephone

You need to start a Unified Manager session to program this feature. For more information about programming using the Unified Manager, see the *Business Communications Manager Programming Operations Guide*.

Auxiliary ringer

An auxiliary ringer is an optional device connected through a RJXX connection to your system. The auxiliary ringer is best suited to factory type locations that require loud ringing bells or horns.

Turn the auxiliary ringer on or off

You need to start a Unified Manager session to program this feature. For more information about programming using Unified Manager, see the *Business Communications Manager Programming Operations Guide*.

Your installer can program the auxiliary ringer to start ringing for incoming lines as part of Ringing Service.

Host System dialing signals

You can access host systems, such as private branch exchanges (PBX) from the system by using host system signaling features (known as end-to-end signaling). These features either send a special signal to the host system or allow you to program delays required by host systems in external autodial or speed dial sequences.

Link

If you connect the system to a private branch exchange (PBX), you can use a Link signal to access special features. On some telephones, Link is called FLASH.

You can include the Link signal as part of a longer stored sequence on an external autodial button or in a speed dial code. The Link symbol () uses two of the 24 spaces in a dialing sequence.

Prevent a telephone from using Link

You can limit the use of Link on individual telephones. You need to start a Unified Manager session to program this feature. For more information about programming using Unified Manager, see the *Business Communications Manager Programming Operations Guide*.





Note: If you connect the system to a private branch exchange (PBX), you can program Link on a memory button for one-touch access.

Pause

The Pause feature enters a 1.5 second delay in a dialing sequence on an external line. The use of this feature is often required for signaling remote devices, such as answering machines, or when reaching through to PBX features or host systems.





You can program more than one pause in an external autodial or speed dial sequence.

The Pause symbol () uses one of the 24 spaces in a dialing sequence.

For pulse dialing,  inserts a 1.5 second pause into the dialing sequence.

Long Tones



The Long Tones feature allows you to control the length of a tone to signal devices such as fax or answering machines which require tones longer than the standard 120 milliseconds.

1 While on a call, press    .

- 2 Press the dial pad buttons to produce the appropriate tones. Each tone sounds while you hold down the button.

You can use Long tones on any call except a conference call. You can use internal lines of the system to activate a device connected to an ATA2 or an ASM in another area of your office, or external lines to access devices outside the system.

Long Tones:

At the appropriate time, press any dial pad button. Hold each button down for as long as necessary. Press  or  to cancel Long Tones.

Run/Stop

Run/Stop inserts a break point into a sequence of dialed numbers or characters used for automatic dialing. This can be necessary when you are connecting to a PBX or similar host system.

For example: you can call a company with an automated attendant that instructs you to dial the internal number you need. You can program the company number, a Run/Stop, then the internal number on one external autodial button. Press the autodial button one time to dial the company number. When you hear the automated attendant, press the autodial button again to dial the internal number.

The Run/Stop symbol () uses one of the 24 spaces in an autodial or speed dial sequence.

You can include up to three Run/Stop commands in a dialing string. The system ignores a fourth Run/Stop, and any digits or commands that follow three Run/Stop commands in a programmed dialing sequence.

Wait for Dial Tone

Wait for Dial Tone causes a sequence of numbers to pause until dial tone is present on the line before continuing to dial. You can use this feature if you must dial a remote system and then wait for dial tone from that system before dialing the remainder of your number.

The Wait for Dial Tone symbol () uses two of the 24 spaces in an autodial or speed dial sequence.

Invalid code

You have entered a code limited to a programmed autodial or speed dial sequence, not on a call you dial directly. Run/Stop are for use in programmed dialing Autodialers only.

Pulse or tone dialing

If your external lines use pulse dialing, you can switch temporarily to tone dialing. Tone dialing allows you to communicate with devices such as answering machines, to access the features that PBX systems can provide, or to access another system remotely.

Press  while on an active line. After you hang up, your telephone returns to pulse dialing.

Pulse dialing for a call

If your external telephone lines use pulse dialing, you can switch to tone dialing by pressing **#** after selecting the line. Tone dialing allows your telephone to communicate with devices and services that respond to tone signals, such as automatic switchboards, and fax or answering machines.

Access your system from an external location

You can use the lines and some of the features of Business Communications Manager from outside the system. You can access the lines and some of the features over the public telephone network when away from the office, or you can call from another system, over a private network.

It is important to maintain the security of your system by limiting access to authorized users and limiting those users to the features they need.

For example, a sales representative out of the office needs to make long distance calls to the European office. Your system has a leased line to Europe with reduced transatlantic charges. You provide the sales representative with a Class of Service password that gives access to the transatlantic line. The sales representative can telephone into the system from a hotel, enter the Class of Service password, and use the leased transatlantic line to make calls.

Remote users can access system lines, line pools, the page feature, and remote administration (if enabled through Software Keys). The exact facilities available to you through remote access vary depending on how your installer set up your system.



Note: If the loop start line used for remote access is not supervised, auto-answer does not function and the caller hears ringing instead of a stuttered tone or the system dial tone.

Direct Inward System Access (DISA)

Control access to your system with direct inward system access (DISA). Access to your system from the public telephone network must be controlled with DISA. If your installer programs the line used for remote access to answer a call automatically and wait for a DISA internal number, callers hear a stuttered dial tone and must enter a Class of Service password before they are allowed into the system.

Class of Service (COS)

To control the level of telephone service a remote user can access, the installer can assign a remote filter and remote package to the line used for remote access. The remote filter limits the numbers dialed on the line, and the remote package limits the use of line pools and the page feature. To change the restrictions for the line, the user can enter their Class of Service password when the system answers with DISA, or dial the DISA internal number and enter their Class of Service password.

Class of Service (COS) passwords

Class of Service passwords permit controlled access to a system's resources both by internal and remote users. When you enter a Class of Service password at a telephone, the restriction filters related with your Class of Service password apply, instead of the normal restriction filters. In the same way, when a remote user enters a Class of Service password on an incoming auto-answer line, the restriction filters and remote package related with their Class of Service password apply, instead of the normal restriction filters and remote package. The installer programs the COS passwords.

Users must memorize their COS passwords instead of writing the password down. Delete an employees' COS passwords when they leave the company. Normally, each user has a separate password. However, several users can share a password or one user can have several passwords.

Change your Class of Service

Enter a Class of Service password when you want to make a call normally restricted on a line or telephone.

To change the restriction filters on a line or telephone:

- 1 Press **[*] 6 8**.
- 2 Enter the six-digit COS password.

COS passwords allow you to define individual passwords and determine the restriction filters, and remote package related with each.

Maintain security

To maintain the security of your system, the following practices are recommended:

- Warn a person to whom you give the remote access number, to keep the number confidential.
- Change Class of Service passwords often.
- Warn a person to whom you give a Class of Service password, to remember the password and not to write it down.
- Delete the Class of Service password of a person who leaves your company.



Warning: Remote users can make long distance calls.

Remember that a remote user can make long distance calls that are charged to your company. They can also access line pools and make page announcements in your office.

Remote access over the public network

- 1 Dial the system remote access number.
- 2 When you hear a stuttered dial tone, enter your COS password.

3 Wait for the system dial tone.

To use the system at a distance, you must use a telephone with tone dialing to call the system. Remote access is possible only on lines that your installer programs to auto-answer calls.

To use features on a remote system, press ***** followed by the feature code. When you are calling from within Business Communications Manager, press ***** instead of **☎**.

In some conditions, you can experience lower volume levels when using the system from a distance.

Tones

You can hear some of the following tones when accessing Business Communications Manager from a distance. Table 8 shows the different types of tone and what they mean. See [“Tones and what they mean” on page 112](#).

Table 8 Tones and what they mean

Tone	What it means
System dial tone	You can use the system from a distance.
Stuttered dial tone	Enter your COS password.
Busy tone	You have dialed a busy line pool access code. You hear system dial tone again after 5 seconds.
Fast busy tone	You have done one of the following: Entered an incorrect COS password. Your call disconnects after five seconds. Taken too long while entering a COS password. Your call disconnects after five seconds. Tried to use a line pool or feature not permitted by your Class of Service. You hear system dial tone again after five seconds. Dialed a number in the system which does not exist. Your call disconnects after five seconds.

Voice mail

If you subscribe to Voice Messaging, you can access that service through Business Communications Manager. A software keycode is required for Voice Messaging. Your installer programs your telephone to indicate when you have a voice message waiting on a specific line.

When you select an extension number from the **Terminals & Sets** programming level, a Mailbox Configuration button appears. Press the button to start a Voice Applications Manager session. The Mailbox configuration button allows you to access the Voice Applications Manager without having to exit Unified Manager. Add the mailbox and close the window to return to the Unified Manager. For more information about configuring a mailbox, see the *Business Communications Manager Programming Operations Guide*.

Similarly, when you select a line number from the **Lines** programming level, a voice mail settings button appears. Press the button to start a Voice Applications Manager session. The voice mail settings button allows you to configure voice mail line settings and then continue programming other line parameters in Unified Manager. For more information, see the Business Communications Manager Programming Operations Guide.

Service provider features

Features from your service provider include:

- Call Forward
- Automatic Call Back
- Automatic Recall

Call Forward

Call Forward allows you to forward incoming calls to an external telephone number. Ask your service provider for the appropriate Call Forward feature code.

- 1 Select an ISDN line by selecting a line button, a line pool, or the Handsfree button, or by lifting the handset (if an ISDN line is your prime line).
- 2 Enter the Call Forward feature code. Listen for three tones followed by dial tone.
- 3 Enter the number of the telephone where you want to forward your calls. If the call is answered, remain on the line for at least five seconds to activate the Call Forward feature.

Cancel Call Forward

- 1 Select an ISDN line by selecting a line button, a line pool, or the Handsfree button, or by lifting the handset (if an ISDN line is your prime line).
- 2 Enter the feature code to cancel Call Forward. Listen for a series of tones.
- 3 Press .

Call the number where your calls are forwarded

- 1 Select an ISDN line by selecting a line button, a line pool, or the Handsfree button, or by lifting the handset (if an ISDN line is your prime line).
- 2 Enter the feature code.

Automatic Call Back

If you call a number and it is busy, enter the appropriate feature code assigned by your service provider to receive ringing notification when the line becomes available. The Automatic Call Back ring type is different from your normal telephone ring type.

Automatic Recall

Automatic Recall allows you to automatically dial the number of the last call you received. You cannot see the number on the display if the information is not available from your service provider, or when you do not have Caller ID in your ISDN service. Ask your service provider for the appropriate feature code.

Chapter 13

Hospitality Services

Hospitality Services (HS) is a group of features that increases the value of Business Communications Manager. The Hospitality Services feature is used in small to medium sized facilities such as hotels, motels, or hospitals.

In a hotel setting, guests gain improved services through immediate access to basic functions such as:

- wake-up service or reminders
- accurate tracking of the room's service requirements

Types of telephone set

Telephones in your system are assigned as one of three types of sets:

- common set
- room set
- Hospitality Services (HS) admin set.

Common set

A common set can be a telephone found in a lobby, office, or common area not associated with a room. A common set does not have access to all of the HS features.

Room set

You need to start a Unified Manager session to assign a Room set to a room. You can assign up to five sets to the same room which then share the same room number. For more information about programming using Unified Manager, see the *Business Communications Manager Programming Operations Guide*.

Hospitality Services (HS) admin set

A Hospitality Services (HS) admin set is any two-line display telephone in the system. You can program an HS admin set to require a user to enter the Desk admin password before accessing HS admin features. For more information about programming an admin set, see the *Business Communications Manager Programming Operations Guide*.

Alarm time (AL) feature

The Alarm time feature provides an alarm clock capability on both room sets and common sets which can be programmed to sound an audible alert at a requested time.

One Alarm time within a 24 hour period is programmable on a room or common set and must be reset daily. When the alarm sounds, all sets in a given room ring. If you cancel the alarm on any set, it cancels the alarm on all the sets in the room. A new Alarm time entered on a room or common set overwrites any alarms previously assigned.

If the system experiences a power failure, this can result in missed Alarm times. When the system is running and the system time resets, the missed Alarm times ring in respective room or common sets. The system allows a maximum of 25 sets with alarms.

Program the Alarm time feature

To program the Alarm time feature on a telephone:

- 1 Press **[☎] [8] [7] [5]**.

The display shows **Alrm: 07:00am OFF**. If the alarm time is correct press **ON**.

The display shows **Alrm:07:00am ON**.

- 2 Press **DONE** to exit.

or

To enter a new alarm time press **CHG**. The display shows **Enter time:**. Enter a new 4 digit alarm time.

When using the 24 hour clock format (hour: 00 to 23 and minutes: 00 to 59), no confirmation is required. The display shows **Alarm ON hh:mm**.

When using the 12 hour format, the display shows **hh:mm AM or PM?**. Press the AM or PM display button. The display shows **Alarm ON hh:mm**.

To program the Alarm time feature on an analog telephone:

- 1 Press **[☎] [*] [8] [7] [5]**. A tone sounds.

- 2 Enter a 4 digit alarm time.

When using the 24 hour clock format (hour: 00 to 23 and minutes: 00 to 59), a tone sounds.

When using the 12 hour format, press **[*]** to select am, or **[#]** to select pm. A tone sounds.

At the assigned times, the set in the room rings to wake-up or remind the occupant of the next event or meeting.

Change or cancel an Alarm time

When you enter a new Alarm time it overwrites any times previously assigned. If you cancel the Alarm time for any set, it cancels the Alarm time for all the sets in the same room.

Cancel an alarm

- Press **[☎] [#] 8 7 5** to cancel the Alarm time on a telephone with a display. The display shows **Alarm OFF**.
- Press **[Link] [#] 8 7 5** to cancel the Alarm time on an analog telephone.

Turn off an Alarm

To release a ringing alarm:

- On a telephone with a display, press any button except the **[☎]** button.
- On an analog telephone, lift the handset and then hang up.



Note: If the user presses the **[☎]** button when the set rings, it temporarily deactivates the Alarm. After a number of minutes, the set will ring again. If the user is on a call when the alarm rings, press any button except **[☎]** to cancel the alarm and maintain the active call.

Hospitality Services admin alarm feature

Only a Hospitality Services (HS) admin set can use the Hospitality Services admin alarm feature. The Hospitality Services admin alarm feature is room oriented only. It does not control the alarms on common sets.

The Hospitality Services admin feature can:

- determine the current or last alarm time set for a room
- overwrite previous Alarm time programming for a room in the system
 - assign an Alarm time for any room
 - change an Alarm time for any room
 - cancel an Alarm pending for any room

To program the Alarm time for a room with the Hospitality Services admin alarm feature:

- 1 Press **[☎] 8 7 7** on a T7316 or M7324(N) two-line display telephone.
- 2 If configured, the display shows **Password:**. Enter the Desk admin password.
- 3 The display shows **Al of rm#:**. Enter the room number and press **OK**.
- 4 Press **VIEW**. The display shows **Alarm: 07:00am OFF:**. If the alarm time is correct press the **ON/OFF** display button to activate the alarm.
- 5 Enter a four-digit alarm time.

If the 24 hour format is used (hour: 00 to 23 and minutes: 00 to 59), no confirmation is required. The display shows **Alarm hh:mm ON**.

If the 12 hour format is used, the display shows the four digit time plus **AM** or **PM?**. Press the **AM** or **PM** display button. The display shows **Alarm hh:mm am ON** or **Alarm hh:mm pm ON**.
- 6 Press the **[☎]** button to exit programming.

Room occupancy





The Room occupancy (RO) feature allows front desk operators to assign dialing restrictions to room sets, and works with the Room condition (RC) feature. The RO feature does not apply to common sets. Dialing restrictions for room sets are defined in Unified Manager. For more information, refer to the *Business Communications Manager Programming Operations Guide*.

The RO feature uses the following room states: Vacant filter, Basic filter, Mid filter, and Full filter. A variety of dialing filters can be configured for each room state. The default setting is Vacant.

- Vacant — Room is empty.
- Basic — Room is occupied.
- Mid — Room is occupied.
- Full — Room is occupied.

Programming the state of a room set

To access the Room Occupancy feature and assign the state of a room set:

- 1 Press     on a T7316 or M7324(N) two-line display telephone.
- 2 If configured, the display shows **Password:**. Enter the Desk admin password.
- 3 The display shows **oc of rm#:**. Enter the room number and press **OK**.
- 4 The display shows **rrrrr:Vacant**. Press the **CHANGE** display button and select the required status for the room set: Vacant, Basic, Mid or Full. The default setting is Vacant.
- 5 To program other rooms, press the **FIND** or **NEXT** display button and return to step 3. If no more rooms require programming, press the  button to exit programming.



Note: Programming a room to Vacant state cancels any outstanding alarms.

Room condition

The Room condition (RC) feature allows users to exchange information about the serviced state of a room. Users are front desk attendants, and cleaning or maintenance personnel of an establishment. The RC feature is not available from a common set.

The system maintains a database of the state of each room. This database is accessed from either the room set or a Hospitality Services admin set.

Room sets can:

- assign the associated room state to Service done (**Srvc done**)
- assign the associated room state to Needs service (**Needs srvc**)
- query the state of the associated room on a set with a display

Front desk sets can:

- assign any room state to Service done (*Srvc done*)
- assign any room state to Needs service (*Needs srvc*)
- query the state of any room

The system changes the state of occupied rooms to Needs service on a daily basis at a time assigned in configuration.

Maintenance personnel change the condition of the room to Service done when service in the room is complete.

The front desk attendant can query or program the condition of a room with a Hospitality Services admin set. The system automatically assigns the status of a room to *Needs srvc*, when a room occupancy status changes from occupied to vacant.

Room condition from a room set

To update the room condition using a room set:

- 1 Press **[☎] 8 7 6** on a two-line display telephone or press **[Link] * 8 7 6** on an analog telephone.
- 2 At the prompt, enter the status of the room.
- 3 Press **[1]** on the dialpad to indicate *Set to srvc done*.
If required, enter the room condition password.
or
Press **[2]** on the dialpad to indicate *Set to needs srvc*.
If required, enter the room condition password.
- 4 The display shows *Set to srvc done* or *Set to needs srvc*.

Room condition with a Hospitality service admin set

To update or query the room condition using a HS admin set:





- 1 Press **[☎] 8 7 8** on a T7316 or M7324(N) two-line display telephone.
- 2 If configured, the display shows *Password#:*.
Enter the desk admin password.
- 3 The display shows *Cd of rm#:*.
Enter the room number and press **OK**.
- 4 The display shows *rrrrr:Vacant*.
Press the **CHANGE** display button and select the required status for the room set:
 - If the room is occupied, select *Srvc done* or *Needs srvc*.
 - If the room is vacant, select *Vacant* or *Needs srvc*.
The default setting is *Vacant*.

- 5 To update or query other room set, press the **FIND** or **NEXT** display button and return to step 3. If there are no more room sets updates or queries, press the  button to exit programming.





Hospitality passwords

The Hospitality Services feature allows for two types of passwords to access different areas of Hospitality programming.

Desk admin password

Use the Desk password to access all Hospitality Services admin features. The default desk password is:     (4677). You need to start a Unified Manager session to program to changes the default desk password. For more information about programming using Unified Manager, refer to the *Business Communications Manager Programming Operations Guide*.

Room condition password

The room condition password controls the ability to change the room condition using    . The default room condition password is None. The room condition password may remain as None.

To change the default room condition password you need to start a Unified Manager session. For more information about programming using Unified Manager, refer to the *Business Communications Manager Programming Operations Guide*.

Chapter 14

Portable telephone and handset features

There are three portable telephones supported by Business Communications Manager: the Companion C3050 Etiquette, Companion C3060 Portable, and the Companion C3050 CT2Plus.

There are two portable handsets supported by Business Communications Manager: the DECT C4010 Handset, and the DECT C4020 Handset. These handsets have region-based availability. For more information about DECT, refer to the *Business Communications Manager DECT Installation and Maintenance Guide*.

Portable telephones

Your portable telephone communicates with Business Communications Manager using radio waves. The radio transceivers for the system are located in the base stations installed at your office. Each base station contains two radio transceivers and can handle two portable telephone calls at the same time.

Not only can you start a telephone conversation anywhere in the office, you can continue that conversation while you walk throughout the building. As you move from one part of your office to another, your call passes from one base station to the next.

If there is a decrease in voice quality while you are moving with a portable telephone, you may be moving out of range from your system base stations. There are three possible reasons for this:

- The base stations that cover the area you are moving into are busy or unable to pick up your call.
- Large pieces of furniture or movable partitions block the signal between you and the base station.
- You have moved out of the range covered by your system.
(Retrace your steps until you are back in range.)

In *rare* instances, during a Message session, softkey display prompts on your portable may disappear. This is a normal condition and is improved by staying within range of a base station.

While you are moving within range, you may hear a slight clipping during a call. Clipping occurs as a call is handed off from one base station to the next.

Problems with lost connections are rare, but if you notice an increase in occurrences, your base stations may need to be moved or reprogrammed. Contact your installer to change the base station configuration. (In the U.S. you need to obtain UTAM Inc. approval before making changes to the base station configuration.) For more information, refer to *Business Communications Manager Programming Operations Guide*.



Note: If you try to send a message from a desk telephone to a portable telephone, the display of the desk telephone shows `Can't send msg`.

Portable telephone features

It is possible to use many of the same system features available to a Business Communications Manager telephone on your portable telephone. The table below shows the features available for use on a portable telephone. For more information about features and the special codes required to use them, refer to the feature card that came with your portable telephone. Table 9 shows the features available to a portable telephone. See [“Features available to a portable telephones in the system” on page 122](#).

Table 9 Features available to a portable telephones in the system

Feature	Description
Call Forward	Send calls to another telephone in your system. The display does not indicate that calls are being forwarded. Hunt Group calls override all Call Forward features. A Hunt Group extension can be a Call Forward destination.
Call Information	The display shows the name or extension of an internal caller. If your system is equipped to receive CLASS information (Caller ID), the external call information appears on the display.
Call Park	Park a call.
Call Park Retrieval	Retrieve a parked call.
Cancel Call Forward	Cancel the Call Forward feature, where calls are automatically sent to another telephone in the system.
Conference	Create a three-way call.
Directed Call Pickup	Answer any telephone that is ringing in the system.
Group Pickup	Answer a call ringing on another set within the same pickup group.
Host system signaling	Use link and pause.
Line Pool	Use line pools the same way a desk telephone does.
Mute	Prevent other callers from hearing you. Also, you can mute incoming calls from ringing on a portable telephone.
Page	Page an individual telephone, several telephones, external speakers, or the entire system. A Hunt Group extension cannot be in a page zone.
Pause	Program an external autodial sequence to insert a 1.5 second delay.
Prime line	On your portable, this may be either an Intercom Line, an Assigned Line or a Line Pool.
Privacy	In programming, change the privacy setting for an external line assigned to the portable. This does not give the ability to change the privacy setting on a call by call basis.
Release	End a call or programming session.

Table 9 Features available to a portable telephones in the system

Feature	Description
Speed Dial	System speed dial codes only. No personal speed dial codes. The portable directory can store up to 50 telephone numbers.
Switching between two calls	Put one call on hold and speak to another caller.
Transfer	Transfer a call to another telephone.
Transfer using directory	Transfer a call using your portable telephone directory.
Trunk Answer	Answer a ringing call for lines placed in a Service Mode.
Wireless Portable Language Selection	Change the language of the prompts that appear on the portable telephone display.
Wireless Call Forward No Answer	Forward a call without ringing. The portable user can answer a call but it does not ring.

Directed Call Pickup

You must enable the Directed Call pickup feature before it can be used. For more information about the Directed Call pickup feature, refer to the *Business Communications Manager Programming Operations Guide*.

Group Pickup

Group Pickup allows the portable user to answer a call ringing on another telephone within the same pickup group. For more information, refer to the *Business Communications Manager Programming Operations Guide*.

Wireless Portable Language Selection

This feature allows you to change the language of the voice prompts and the prompts that appear on the portable telephone display.

The system supports a primary default language and three alternate languages.

Press	*	*	5	0	1	Language - Primary
Press	*	*	5	0	2	Language - Alternate
Press	*	*	5	0	3	Language - Alternate 2
Press	*	*	5	0	4	Language - Alternate 3

Wireless Call Forward No Answer enhancement

This feature prevents a portable telephone from ringing when the call is forwarded to a new destination. The portable user can answer the call, even though it does not ring. For more information, refer to the *Business Communications Manager Programming Operations Guide*.

Chapter 15

Troubleshooting

This chapter describes alarm codes and how to use them. It also show you how to test your telephone.

Alarm codes

An alarm telephone display shows Business Communications Manager system alarm codes when they occur. The installer assigns alarms to T7316 or M7324(N)two-line display telephones.

Report and record alarm codes

If an alarm message appears on the alarm telephone display:

- 1 Record the alarm number.
- 2 Call your customer service representative and report the alarm code.

Alarm: 61-42
TIME

Report this alarm and the time it occurred to your installer or customer service representative.



Note: Alarms are also stored in the WinNT Network Event log. For more information, see the *Business Communications Manager Programming Operations Guide*.

Test the telephone

If you know something is wrong with a button, the speaker, the displays, or some other part of the telephone hardware, you can do a quick test to see which part of the telephone is not functioning properly.

Test the telephone display



To test the telephone display:

- 1 Press **[*] [8] [0] [5]**. The display shows **Display test**.
- 2 Press **TEST**.
- 3 Adjust the contrast level for the telephone display so you can clearly see the test results. The contrast level ranges from one to nine. Enter a number to change the contrast or press **DOWN** and **UP**.

- 4 Press **OK** or  to go ahead with the test.
During the test, the display shows solid, dark blocks and all the indicators next to the buttons on the telephone. Any Busy Lamp Field (BLF) or CAP modules connected to the telephone must be completely lit. You lose any information which appeared on the BLF before the test started.
- 5 Press any button to end the test.

Test the telephone buttons

To test the telephone buttons:

- 1 Press  **8** **0** **5**. The display shows **Display test**.
- 2 Press **NEXT**. The display shows **Button test**.
- 3 Press **TEST**. Press each button to determine its function. If the button you pressed uses an indicator, it must light when you test the button.
- 4 When you press the  button, **Rls button** appears on the display. Press  again to end this test.

Test the speaker in the telephone handset

The handset test is not available when a headset is plugged into the telephone.

- 1 Press  **8** **0** **5** and **NEXT** twice. The display shows **Handset test**.
- 2 Press **TEST**.
- 3 Pick up the handset and listen. You can hear dial tone through the handset at a maximum volume. The volume is reset to maximum only while the test is in progress.
- 4 Press any button to end the test.

Test the telephone headset

The headset test is only available to telephones with a headset.

- 1 Press  **8** **0** **5** and **NEXT** until the display shows **Headset test**.
- 2 Press **TEST**. You hear dial tone through the headset. The volume resets to the default level during this test.
- 3 Press any button to end the test.





Test the telephone speaker

To test the telephone speaker:





- 1 Press  **8** **0** **5** and **NEXT** until the display shows **Speaker test**.

- 2 Press **TEST**.
You hear a page tone through the telephone speaker at the maximum volume. The volume returns to its previously assigned level at the end of the test.
- 3 Press any button to end the test.

Test the power supply to a telephone

- 1 Press     and **NEXT** until the display shows **Power test**.
- 2 Press **TEST**.
All the indicators on the telephone light and the telephone rings at maximum volume. When the test ends, the display shows **Power OK**. The test continues for five seconds or until you press a button.



Note: Make sure the function of a button matches the label by pressing    and then the button. Press  to end the telephone testing session. The test feature times out after three minutes of inactivity.

Appendix A

Feature Codes

This appendix provides a quick reference for Business Communications Manager features available by pressing the  button and entering a code. Table 10 provides feature names sorted in alphabetical order and Table 11 is sorted numerically by feature code. See [“Features sorted by feature name” on pag e129](#) and [“Features sorted by activation code” on page133](#) .

Table 10 Features sorted by feature name



























Feature name	Activation code
ACD agent login/log out	 9 0 4
ACD agent make busy/ready	 9 0 8
ACD queue status	 9 0 9
Alarm time	 8 7 5
Alarm time - Cancel	 # 8 7 5
Alarm time (HS admin set)	 8 7 7
Autodial - External	 * 1
Autodial - Internal	 * 2
Background Music	 8 6
Background Music - Cancel	 # 8 6
Button inquiry	 * 0
Call Charge Indication	 8 1 8
Call Duration Timer	 7 7
Call Forward	 4
Call Forward - Cancel	 # 4
Call Forward to Voice Mail	 9 8 4
Call Information	 8 1 1
Call Log - Delete items (Auto Bumping)	 8 1 5
Call Log - Manual	 8 1 3
Call Log - View information	 8 1 2
Call Log options	 * 8 4
Call Log password	 * 8 5
Call Park	 7 4
Call Queuing	 8 0 1
Camp-on	 8 2
Class of Service	 6 8

Table 10 Features sorted by feature name (Continued)

Feature name	Activation code
Conference Call	* 3
Contrast adjustment	* * 7
Dialing Mode	* * 8 2
Directed Pickup	* 7 6
Display Voice Mail DN	* 9 8 5
Do not Disturb	* 8 5
Do not Disturb - Cancel	* # 8 5
Exclusive Hold	* 7 9
Express Messaging	* 9 8 0
Group Listening	* 8 0 2
Group Listening - Cancel	* # 8 0 2
Group Pickup	* 7 5
Language - Primary ¹	* * 5 0 1
Language - Alternate ¹	* * 5 0 2
Language - Alternate 2 ¹	* * 5 0 3
Language - Alternate 3 ¹	* * 5 0 4
Last Number Redial	* 5
Line buttons - Move	* * 8 1
Line Pool	* 6 4
Line Redirection	* 8 4
Line Redirection - Cancel	* # 8 4
Link	* 7 1
Long tones	* 8 0 8
Malicious call identification (MCID)	* 8 9 7
Memory buttons - Program	* * 3
Messages - Send	* 1
Messages - Cancel Send	* # 1
Messages - View	* 6 5
Name and number blocking	* 8 1 9
Name and number blocking - Cancel	* # 8 1 9
Page	* 6 0
Page - Combined (internal & external)	* 6 3
Page - External (external speakers)	* 6 2

Table 10 Features sorted by feature name (Continued)

Feature name	Activation code
Page - Internal (telephone speakers)	* 6 1
Pause	* 7 8
Priority Call	* 6 9
Privacy (on/off)	* 8 3
Ring Again	* 2
Ring Again - Cancel	* # 2
Ring Type	* * 6
Ring Volume	* * 8 0
Ringing (Signal) Call	* 8 0 7
Room condition (Room set)	* 8 7 6
Room condition (HS admin set)	* 8 7 8
Room occupancy	* 8 7 9
Run/Stop	* * 9
Saved Number Redial	* 6 7
Speed Dial - Add, change	* * 4
Speed Dial - Activate	* 0
Static Time	* 8 0 6
Static Time - Cancel	* # 8 0 6
Test telephone display	* 8 0 5
Time	* 8 0 3
Transfer	* 7 0
Transfer - Cancel	* # 7 0
Transfer to mailbox	* 9 8 6
Trunk Answer	* 8 0 0
Turning Restriction service off	* # 8 7 2
Turning Restriction service on ²	* 8 7 2
Turning Ringing service off	* # 8 7 1
Turning Ringing service on	* 8 7 1
Turning Routing service off	* # 8 7 3
Turning Routing service on ²	* 8 7 3
View active services	* 8 7 0
Voice Call	* 6 6
Voice Call Deny	* 8 8

Table 10 Features sorted by feature name (Continued)

Feature name	Activation code
Voice Call Deny - Cancel	* # 8 8
Voice Mail Interrupt	* 9 8 7
Voice Mail login	* 9 8 1
Voice Mail Operator settings	* 9 8 2
Wait for dial tone	* 8 0 4
Notes	
¹ For the Companion C3050 Etiquette, C3060 Portable, and C3050 CT2Plus portable telephones, enter * * followed by the numeric code to activate this feature.	
² Contact your System Administrator for the Service control password.	

Features sorted by activation code

Table 11 Features sorted by activation code

Activation code	Description
0	Speed Dial - Activate
* 0	Button inquiry
1	Messages - Send
# 1	Messages - Cancel Send
* 1	Autodial - External
2	Ring Again
# 2	Ring Again - Cancel
* 2	Autodial - Internal
3	Conference Call
* 3	Memory buttons - Program
4	Call Forward
# 4	Call Forward - Cancel
* 4	Speed Dial - Add, change
5	Last Number Redial
* 6	Ring Type
* 7	Contrast adjustment
* 9	Run/Stop
6 0	Page
6 1	Page - Internal (telephone speakers)
6 2	Page - External (external speakers)
6 3	Page - Combined (internal & external)
6 4	Line Pool
6 5	Messages - View
6 6	Voice Call
6 7	Saved Number Redial
6 8	Class of Service
6 9	Priority Call
7 0	Transfer
# 7 0	Transfer - Cancel
7 1	Link
7 4	Call Park

Table 11 Features sorted by activation code (Continued)

Activation code	Description
*75	Group Pickup
*76	Directed Pickup
*77	Call Duration Timer
*78	Pause
*79	Exclusive Hold
*80	Ring Volume
*81	Line buttons - Move
82	Camp-on
*82	Dialing Mode
83	Privacy (on/off)
84	Line Redirection
#84	Line Redirection - Cancel
*84	Call Log options
85	Do not Disturb
#85	Do not Disturb - Cancel
*85	Call Log password
86	Background Music
#86	Background Music - Cancel
88	Voice Call Deny
#88	Cancel Voice Call Deny
*501	Language - Primary ¹
*502	Language - Alternate ¹
*503	Language - Alternate 2 ¹
*504	Language - Alternate 3 ¹
800	Trunk Answer
801	Call Queuing
802	Group Listening
#802	Group Listening - Cancel
803	Time
804	Wait for dial tone
805	Test telephone display
806	Static Time
#806	Static Time - Cancel

Table 11 Features sorted by activation code (Continued)

Activation code	Description
*807	Ringing (Signal) Call
*808	Long tones
*#809	Name and number blocking - Cancel
*811	Call Information
*812	Call Log - View information
*813	Call Log - Manual
*815	Call Log - Delete items (Auto Bumping)
*818	Call Charge Indication
*819	Name and number blocking
*870	Viewing active services
*871	Turning Ringing service on
*#871	Turning Ringing service off
*872	Turning Restriction service on ²
*#872	Turning Restriction service off
*873	Turning Routing service on ²
*#873	Turning Routing service off
*875	Alarm time
*#875	Alarm time - Cancel
*876	Room condition (Room set)
*877	Alarm time (HS admin set)
*878	Room condition (HS admin set)
*879	Room occupancy
*897	Malicious call identification (MCID)
*904	ACD agent login/log out
*908	ACD agent make busy/ready
*909	ACD queue status
*980	Express Messaging
*981	Voice Mail login
*982	Voice Mail Operator settings
*984	Call Forward to Voice Mail
*985	Display Voice Mail DN
*986	Transfer to mailbox

Table 11 Features sorted by activation code (Continued)

Activation code	Description
☎ 9 8 7	Voice Mail Interrupt
<p>Notes</p> <p>¹ For the Companion C3050 Etiquette, C3060 Portable, and C3050 CT2Plus portable telephones, enter ☎ * * followed by the numeric code to activate this feature.</p> <p>²Contact your System Administrator for the Service control password.</p>	

Appendix B

Common display prompts and error messages

The following display prompts and error messages can appear when using a telephone connected to Business Communications Manager.

Access denied	Programming is busy, or the feature you are trying to use is not compatible with the configuration of the telephone or line.
Denied in admin	You are trying to use a feature, but do not have access to it under administration.
Feature timeout	You took more than 15 seconds to press a button in response to a display.
Inactive feature	You entered the feature code for an application that is disabled.
Invalid code	You entered an invalid feature code.
Not available	You tried to use a feature that is currently not available from your system.
Set locked	You cannot use the feature you selected because your telephone is locked. See “Set lock” on page 107 .
1234567890123... VIEW OK	Press # or press VIEW or +VIEW to view a number that is too long to fit on the display. Press OK when you have finished.
\$	This indicates a long distance call. (May be available with Call Display services.)
239>221	You are receiving an internal call from extension 239 forwarded by extension 221, or you have an Answer button for extension 221 and an internal call from 239 is ringing on 221.
221 TRANSFER	You are connected to an internal call. Press TRANSFER to transfer the call.
221 calling	You are receiving a call from extension 221.

<p>Call 221? YES NO</p>	<p>You have received a Ring Again offer from a call to an internal telephone. Press the flashing internal line button or <u>YES</u> to call the number again. On the T7100 telephone, just lift the handset. Otherwise, press <u>NO</u> or wait 30 seconds for the Ring Again offer to expire. See “Ring Again” on page 44.</p>
<p>Camped: 221 CALLBCK</p>	<p>The person at extension 221 has not answered the camped call. The call has come back to you. Press the line button or <u>CALLBCK</u> to reconnect to the call.</p>
<p>Line061 TRANSFR</p>	<p>You are connected to an external call. Press <u>TRANSFR</u> to transfer the call.</p>
<p>Line061>221</p>	<p>You are receiving an external call forwarded from extension221, or you have an answer button for extension221 and an external call is ringing on that telephone.</p>
<p>Line061 transfer</p>	<p>Another user in the system is transferring a call to you on line 061.</p>
<p>Line061 waiting</p>	<p>A camped call is waiting. Press the line button or use Call Queuing to answer the call. Press  if you have a T7100 telephone.</p>
<p>No calls waiting</p>	<p>You tried to use Call Queuing but no call was ringing at your telephone.</p>
<p>No line selected</p>	<p>There is no call ringing at your telephone. If you have a flashing line button but your telephone is not ringing, press the line button to answer the call on that line.</p>
<p>Not in service</p>	<p>The telephone where you directed a call is not in service or is unavailable. The call returns to your telephone.</p>
<p>Parked call CALLBACK</p>	<p>No one answered the call you parked. The call returns to you.</p>
<p>Pick up receiver</p>	<p>You have used the Call Queuing feature without picking up the handset. Auto Handsfree is not been assigned to your telephone. You must use the handset or press the handsfree button to answer a call.</p>

Priority> 221 BLOCK	You are receiving a priority call. If you are on another call, tell the person you are speaking to that you are about to put the call on hold. Press the flashing line indicator of the priority call or wait until the call connects automatically (in eight seconds). The priority call goes through after you hear the next beep. Your active call is on Exclusive Hold. It reconnects automatically when the priority call ends (unless you transfer the priority call, in which case you must press the line button of your original call to reconnect). Use DND (<input type="checkbox"/> 8 <input type="checkbox"/> 5) or press BLOCK to reject a priority call.
Release a call	You have no free line available to receive a call. Release one of your current calls and try again to answer the incoming call.
Use line Pool? YES NO	You received a Ring Again offer for a line pool. Press the flashing internal line button or YES to use the line pool. On the T7100 telephone, lift the handset. Otherwise, press NO or wait 30 seconds for the Ring Again offer to expire.
Hold or release	While on a call, you must either release the call or put the call on hold before you can program a feature button.
Release calls	You tried to use a feature while you were on a call or had calls on hold. Release the call or calls, before using the feature.
Line in use	The line is in use. Make the call using normal methods or wait until a line is free.
No button free	You tried to make, receive or pick up a call when no line button was available. Some features require you to have a button free. Releasing calls can free up line buttons.
Make calls first	The feature you tried to use requires you to be on an active call at your telephone. This prompt also appears when information about a call is cleared by a system reset.
No free lines	All the lines or line pools available to the telephone are in use. This prompt also appears when you try to dial an external number or use a feature that conflicts with the lines, line pools or prime line used by the telephone. Your installer must correct this situation.
No line selected	The telephone is set up to dial an external number on a prime line but the telephone does not have a prime line. Your installer must correct this situation.
In use:221	You tried to program redirection while the feature is in use. Only one person can program line redirection at a time.

Incoming only The line you are trying to use to redirect calls is for incoming calls only. Select an outgoing line.

9_
QUIT BKSP OK Continue entering digits. Press **BKSP** to delete incorrect digits. Press **#** or **OK** when you have finished.

Invalid number You entered an invalid line pool code or an invalid destination code.

Line denied You selected a line that is private to another telephone.

Restricted call The destination you selected for line redirection is restricted.

Index

Symbols

- ☎ Long Distance symbol 137
- 🔗 Link symbol 108
- ⏸ Pause symbol 108
- ⏹ Run/Stop symbol 109
- ⏳ Wait for Dial Tone symbol 109

Numerics

911 15, 95

A

access

- Business Communications Manager from outside the system 110
- Class of Service 111
- external lines 41
- remote 111
- using a COS 110
- using a DISA 110

Access denied 137

acronyms 16

ADD 26

Admin alarm time 117

Alarm 61-42 125

alarm codes, reporting and recording 125

alarm telephone 125

Alarm time 116

- admin 117
- cancelling 117
- changing or cancelling 116
- programming 116
- turning off 117

Allow calls 96

allow redirect

- programming 66

Already joined 36, 39

Already parked 60

alternate services 102

analog telephone

- replying to a message 73

analog telephones

- sending messages 71

announcement

paging 69

Voice Call 75

Answer button 36

answering calls

- Answer button 36
- Call Display services 30
- Call Duration Timer 99
- Call Pickup 35
- CAP 33
- Conference Calls 45
- Group Listening 37
- Handsfree 97
- hearing aid compatibility 99
- prime telephone 32
- Privacy 96
- Trunk Answer 36
- using line buttons 30
- using the Release button 35
- Voice Call 75

ASM

- using dialing modes 42

ATA

- using dialing modes 42

Auto Call information (see Caller ID set)

Autodial

- for T7100 49
- line selection 49
- programming 49
- storing number on a memory button 49
- using intercom line for 50
- using Last Number Redial 51

Autodial full 50

automatic

- Call information 32
- Call Log 77
- dial 42
- Hold 55
- release of a line (see Disconnect Supervision)

Automatic Call Back, ISDN feature 113

Automatic Call Forward

- changing settings 64

Automatic Recall

- ISDN terminal feature 114

Automatic Telephone Relocation 95, 99

auxiliary ringer 107

B

Background Music 100
turning off 100

BKSP 26

blocking

name and number 101

blocking calls (see Do Not Disturb)

Business Communications Manager

ASM, Long tones 109

ATA, Long tones 109

features 122

system dial tone 112

telephones

installing 20

mounting on a wall 22, 23

busy 39, 44

busy tone, fast 112

button defaults 86

M7324(N) telephone 89

T7100 telephone 90

T7208 telephone 88

T7316 telephone 88

Button erased 50

Button Inquiry 84

buttons

Answer button 36

Button Inquiry 84

display 25, 26

erasing programmed features 85

Feature 25

Hold 25

Last Number Redial 51

memory 25, 27, 49

moving line 90

programming features on 85

Release 25, 35

Saved Number Redial 53

testing 126, 127

using a line button 42

bypassing

a Hotline telephone 106

C

call

blocking 102

overflow 24

ways to make a 39

Call 221? 138

Call blocked 44

Call Display information 31

Call Duration Timer 99

Call Forward

and Line Redirection, differences 66

automatic, changing settings 64

Call Forward on Busy 64

canceling 63

Forward no answer 64

ISDN terminal feature 113

overriding 64

programming 64

to voice mail 65

using 63

Call information

automatic 32

changing what is shown first 32

displaying information 30

for a call on hold 31

for a current call 31

Call Log 77

Autobumping 78

automatic 77

calling from within 79

deleting log items 78

logging a call manually 78

options 77

password 79–80

canceling 80

changing 80

telephone 77

using 77

Call Park 59

Call Pickup

Directed Pickup 35

Group Pickup 35

Call Queuing 56

Call Transfer 56–58

~~Call(s) bumped~~ 80

Callback 61

Caller ID set 32

Calling 44

calls, switching between 123

~~Camp denied~~ 59

~~Camp to~~ 59

~~Camped~~ 59, 138

camping calls (see Camp-on)

Camp-on 58

~~Can't ring again~~ 39, 45

CANCEL 26

-
- Cancel denied 74
 - canceling
 - a transfer 57
 - Call Forward 63
 - Do Not Disturb 96
 - Group Listening 38
 - Line Redirection 67
 - CAP (central answering position)
 - answering calls 33
 - customizing 34
 - M7324 telephone 33
 - monitoring calls 34
 - telephone 33, 105
 - using 33
 - central answering position (see CAP)
 - changing settings
 - automatic Call Forward 64
 - Class of Service
 - changing 111
 - using a password 110, 111
 - Cleared>LINENAM 74
 - clipping 121
 - communicating in the office
 - paging 69–71
 - sending messages using display 71
 - Voice Call 75
 - Conference busy 47
 - Conference Call
 - by releasing privacy 97
 - disconnecting from 47
 - removing yourself from 47
 - splitting 47
 - using the Conference feature 45
 - contrast adjustment 83
 - control telephone 103, 107
 - conventions, text 15
 - customizing CAP 34
 - customizing your telephone
 - adjusting ring volume 84
 - Button Inquiry 84
 - changing ring type 84
 - contrast adjustment 83
- D**
- date and time
 - displayed instead of messages 91
 - displaying 99
 - length of a call 99
 - defaults
 - button assignments 86
 - deleting
 - Call Log items 78
 - messages from list 73
 - programmed features 85
 - Denied in Admin 41
 - Denied in admin 137
 - dial pad
 - description 25
 - dial tone
 - stuttered 112
 - system 112
 - Dial voice call 76
 - dialing
 - automatic dial 42
 - modes 42
 - pre-dial 43
 - saved number 53
 - signal
 - Link 108
 - Long Tones 108
 - Pause 108
 - run/stop 109
 - switching from pulse to tone 110
 - Wait for Dial Tone 109
 - standard dial 42
 - switching from pulse to tone 110
 - direct dial telephone
 - programming 106
 - direct inward system access (DISA) 110
 - Directed Call Pickup 123
 - Directed Pickup 35
 - DISA (see direct inward system access)
 - disconnect
 - from conference 47
 - releasing a call, accidentally 99
 - Supervision 99
 - display
 - buttons 25, 26
 - Call information 31
 - changing the language 83
 - making darker or lighter 83
 - one-line 26, 72
 - time and date 99
 - two-line 26, 72
 - distinctive rings 84
 - DN (see extension numbers)
 - DND 59
 - DND from 32

DND transfer 32

Do Not Disturb 95
canceling 96
on Busy 64
using 96

Do not disturb 39, 44, 57

DRT 32

E

Emergency 911 15

ending a call 35

Enter code 85

Enter digits 50, 52

Enter zone 70

erasing

Call Log items 79
messages from list 73
programmed features 85

Evening Sched 105

Exchanged 90

Exclusive Hold 43, 56

Expensive route 40

extension numbers

length of 23

external

access to Business Communications Manager 110
autodial, programming 49
Call Forward (see Line Redirection)
paging equipment 71

external page 69

extra dial telephone 105

F

Feature

Autobumping

canceling # 8 1 5 78
using 8 1 5 78

autodial button

external * 1 49, 51
internal * 2 49

Background Music

canceling # 8 6 100
turning on 8 6 100

Button Inquiry * 0 23, 53, 84, 127

Call Duration Timer 7 7 99

Call Forward

canceling # 4 63
using 4 63

Call Information Feature 8 1 1 31

Call Log

entering 8 1 2 79
external calls 8 1 3 78
options * 8 4 78
password * 8 5 80
password * 8 5 79
viewing 8 1 2 78

Call Park 7 4 60

Call Pickup 7 6 35

Call Queuing 8 0 1 56

Call Transfer

canceling # 7 0 57
using 7 0 47, 56

Camp-on 8 2 58

Class of Service 6 8 111

Conference Call

T7100 telephone # 3 46, 47
using 3 45, 46, 47

Contrast Adjustment * 7 83

Dialing Modes * 8 2 42

Directed Pickup 7 6 35

Do Not Disturb

canceling # 8 5 96
turning on 8 5 43, 96

Exclusive Hold 7 9 56

Feature Button

programming * 3 85

Group Listening

canceling # 8 0 2 38
using 8 0 2 37

Hide message display * 8 0 6 91

Host System Dialing Signals

Long Tones 8 0 8 108

Last Number Redial 5 51

Line Pool Access 6 4 41

Line Redirection

canceling # 8 4 67
using 8 4 66

Message

canceling # 1 72
sending 1 71, 72, 73
viewing ones you sent 1 74
viewing 6 5 72

Page

combined zone 6 3 69
external zone 6 2 69
internal zone 6 1 69
using 6 0 60, 69

Password

Call Log * 8 5 80

Priority Call 6 9 43

Privacy 8 3 97

Restriction Service

- turning off # 8 7 2 103
- turning on 8 7 2 103
- Ring Again
 - canceling # 2 45
 - using 2 44
- Ring Type * 6 84
- Ring Volume * 8 0 84
- Ringing Service
 - turning off # 8 7 1 103
 - turning on 8 7 1 103
- Routing Service
 - turning off # 8 7 3 103
 - turning on 8 7 3 103
- Saved Number Redial 6 7 53
- Services, viewing 8 7 0 104
- Speed Dial
 - adding user * 4 52
 - making calls 0 51
- Static Time and Date 8 0 6 74
- Testing
 - display 8 0 5 125
 - power supply 8 0 5 127
 - telephone buttons 8 0 5 126
 - telephone handset 8 0 5 126
 - telephone headset 8 0 5 126
 - telephone speaker 8 0 5 126
- Time 7 7 99, 100
- Voice Call Deny
 - canceling # 8 8 76
 - using 8 8 76
- Voice Call 6 6 75
- fast busy tone 112
- feature
 - wireless Call Forward No Answer 123
 - wireless Portable Language Selection 123
- Feature button 25
- Feature code 85
- Feature moved 85
- Feature timeout 137
- Features
 - name 129
- features
 - activation code 133
 - adjusting ring volume 84
 - Autobumping 78
 - autodial 49
 - auxiliary ringer 107
 - Background Music 100
 - Button Inquiry 84
 - Call Display 30
 - Call Duration Timer 99
 - Call Forward 63
 - Call Information 31
 - Call Log 77
 - Call Park 60
 - Call Pickup 35
 - Call Queuing 56
 - Call Transfer 56
 - Callback 61
 - Camp-on 58
 - changing ring type 84
 - Class of Service password 111
 - Conference Calls 45
 - contrast adjustment 83
 - dialing modes 42
 - dialing signal
 - Link 108
 - Long Tones 108
 - Pause 108
 - run/stop 109
 - Wait for Dial Tone 109
 - Do Not Disturb 95, 96
 - Do Not Disturb on Busy 64
 - Exclusive Hold 56
 - Group Listening 37
 - Handsfree 97
 - hiding the message or calls display 91
 - Hold 55
 - Hunt Groups 93
 - ISDN 101
 - language choice 83
 - Last Number Redial 51
 - line pools 41
 - Line Redirection 65–66
 - Messages 71
 - moving line buttons 90
 - paging 69–71
 - priority call 43
 - Privacy 96
 - Restriction service 102
 - Ring Again 44
 - ring type 84
 - Ringing service 102
 - Routing service 102
 - Saved Number Redial 53
 - sending messages using analog telephones 71
 - sending messages using display 71
 - Set Lock 107
 - Speed Dial 51
 - Test a Telephone 125–127
 - Trunk Answer 36
 - Voice Call 75
 - Voice Call Deny 76
- Forward denied 65
- Forward > 65

- forwarding calls
 - Call Forward 63
 - Call Forward delay 64
 - Call Forward No Answer 64
 - Call Forward on Busy 64
 - Do Not Disturb on Busy 64
 - Line Redirection 65–66

G

- Group Listening 37
 - canceling 38
- Group Pickup 35, 123

H

- handling many calls at once
 - Call Queuing 56
 - Hold 55
- handset
 - speaker testing 126
 - testing 126
- Handsfree 90, 97
 - making calls 97
 - muting 98
 - using 98
- Handsfree Answerback
 - programming 99
 - Voice Call 75
- headset
 - testing 126
- hearing aid compatibility 99
- Hidden number 51, 54
- Hidden number 40
- Hold
 - automatic 55
 - button 25
 - Conference Call 46
 - exclusive 56
 - getting information for a call on 31
 - listening while on hold 55
 - retrieving call 55
- Hold or release 81, 139
- Hospitality passwords 120
- Hospitality services 115
- host system signaling
 - Link 108
 - Pause 108
 - run/stop 109
 - Wait for Dial Tone 109
- Hotline

- bypassing 106
- setting up the telephone 106
- Hunt Groups 93, 95, 122
 - Broadcast mode 94
 - Distribution modes 94
 - features 93
 - members of 94
 - Rotation mode 94
 - Sequential mode 94

I

- In use 74, 139
- In use SETNAME 81
- Inactive feature 137
- incoming call indicator 29
- Incoming only 140
- indicator
 - incoming call 29
- Integrated Services Digital Network (ISDN) 101
- Intercom 67
- intercom
 - using as the line for Autodial 50
- Intercom # 50
- internal page 69
- Invalid code 52
- Invalid code 109, 137
- Invalid location 90
- Invalid number 50
- Invalid number 57, 60, 140
- Invalid zone 70
- ISDN PRI
 - Network Name Display 101

L

- language, changing on the display 83
- Last Number Redial
 - programming 51
- Last Number Redial, using 51
- length of call, timing 99
- length of external numbers 23
- limiting
 - access to Business Communications Manager 110
 - telephone feature use 107
 - telephone programming 107
 - using alternate or scheduled services 102
- line

assignment 24
 button
 moving 30, 90
 button, using to choose a line 42
 changing the name 23
 indicators, description 30
 pool 41, 41–42
 Redirection
 canceling 67
 using 65–66
 Redirection, and Call Forward, differences 66
 target 24

 Line 061 waiting 138
 Line denied 36, 40, 140
 Line hung up 59
 Line in use 139
 Line Pools, using 122
 Line Redirection 67
 Line061 callback 32
 Line061 hung up 58
 Line061 to Prime 33
 Line061 transfer 138
 Link
 programming 108
 using 108
 listening on hold 55
 log space
 programming 80
 logging a call manually 78
 Logit (see Call Log)
 long distance call
 indicator 137
 using COS password 110
 Long Tones 109
 lost calls, troubleshooting 122
 Lunch Sched 105

M

M7324(N) telephone
 button defaults 89
 CAP 33
 Conference Call 46
 memory buttons 27
 splitting a Conference Call 47
 troubleshooting 125
 maintaining security 111
 Make calls first 139

making calls
 dialing modes 42
 priority call 43
 using a line button 42
 using line pools 41
 using Ring Again 44
 memory button
 link 108
 programming 42
 memory buttons 25, 27, 49
 Message denied 74
 Message list 74
 Message to 74
 Messages
 canceling a sent message 72
 hiding display 91
 removing from list 73
 sending, using the display 71
 viewing 72
 Messages & Calls 74, 81
 Microphone muted 76
 monitoring
 calls 36
 with CAP 34
 line pool status 44
 telephone status 44
 transferred calls 61
 Move line from 91
 Move line to 91
 moving
 buttons 90
 telephones 95
 music, background 100
 muting voice call tones 75

N

Network Name Display
 PRI 101
 New calls begin 81
 night control phone (see control telephone)
 Night Sched 105
 Night Service (see services)
 9. 140
 No button free 74, 139
 No call on 60
 No call to Park 60
 No calls waiting 138

No free lines 139
No info to log 81
No last number 51
No last number 40
No line selected 40, 138, 139
No line to use 67
No log assigned 81
No number saved 54
No number stored 52, 74
No resume item 81
No services ON 104
No voice call 76
Not available 137
Not in service 40, 58, 59, 65, 138

O

OK 26
On another call 40, 44
On hold 56
one button dialing (see Autodial)
out of range 121
Outgoing line 68
overflow call routing 24
OVERRIDE 26
overriding
 Call Forward 64

P

page
 external equipment 71
 programming 70
 shortcut codes 69
 types 69
 zone 69
 zones
 programming 70
Page choice 70
Page timeout 70
Paging ALL 70
Paging busy 71
paging equipment 71
Park denied 60
Parked call 138
Parked on 60
parking a call

 retrieving 60
Parking full 60
password
 Call Log 79–80
 canceling 80
 changing 80
 Class of Service 111
Pause 108
pause in a sequence of numbers (see Wait for Dial Tone)
Pick up receiver 138
Pickup 36
Pickup denied 36
pickup group 35
Please wait 44
Pool code 68
portable telephone
 and Business Communications Manger 122
 using 121
 voice quality 121
power off, effect on memory buttons 49
power supply, testing 127
pre-dial 43
Press a button 50, 84, 86
Press a line 91
Press held line 47
prime
 line 106
 telephone 32
prime line 24
priority call (see also Call Queuing) 32, 43
Priority denied 44
Priority>223 139
Privacy
 changing status 96
private
 branch exchange, accessing from Business
 Communications Manager (see also host system
 dialing signals) 108
 call 97
 line 24
Program and HOLD 50, 52, 86
Program and OK 50, 52, 86
Programmed 50
programming
 features on buttons 85
 lines
 changing the name of a line 23

- log space 80
 - system 19
 - system features
 - Restriction service 102
 - Ringing service 102
 - Routing service 102
 - System Speed Dial 51
 - telephones
 - allowing Line Redirection 66
 - auxiliary ringer 107
 - Call Display 32
 - Call Forward delay 64
 - Call Pickup 35
 - changing the name of a telephone 23
 - direct dial telephones 106
 - Do Not Disturb 95
 - external autodial button 49
 - Forward no answer 64
 - Forward on busy 64
 - Handsfree 98
 - Handsfree Answerback 99
 - Hotline 106
 - page zone 70
 - paging 70
 - priority call 43
 - Redirect ring 67
 - Set lock 107
 - User Speed Dial 51, 52
 - programming telephones
 - Last Number Redial 51
 - Link 108
 - Saved Number Redial 53
 - publications
 - related 17
- Q**
- QUIT** 26
- R**
- range 121
 - Rate Interface
 - Basic (BRI) 101
 - Primary (PRI) 101
 - redialing
 - external number 51
 - ~~Redir by~~ 68
 - Redirect ring
 - programming 67
 - ~~Redirect denied~~ 68
 - redirection loops, avoiding 66
 - refusing to answer second call 96
 - ~~Release a call~~ 59, 139
 - Release button 25, 35
 - ~~Release calls~~ 139
 - Release, using 122
 - releasing
 - accidentally 99
 - from conference 47
 - remote access 110–112
 - remote use
 - Class of Service password 111
 - security 110
 - using lines and features from outside the system 110
 - replying to a message 72
 - analog telephone 73
 - reporting and recording alarms 125
 - Restr'n 104
 - ~~Restricted call~~ 40, 58, 140
 - restricting
 - access to Business Communications Manager 110
 - feature use (see Set Lock)
 - telephone feature use 107
 - telephone programming 107
 - using alternate or scheduled services 102
 - Restriction service 102
 - retrieval codes
 - Call Park 59
 - retrieving
 - held call 55
 - parked call 60
 - ring
 - auxiliary ringer 107
 - changing ring type 84
 - description of types 29, 84
 - ring volume 84
 - Ring Again 44
 - ~~Ring Again?~~ 40, 45
 - Ringing 104
 - Ringing service 102
 - RLS button 35
 - Room condition 118
 - Room Occupancy 118
 - state of room 118
 - Routing 104
 - Routing service 102
 - run/stop signal 109

S

Saved Number Redial
 using 53

Saved Number Redial, programming 53

saving a number (see Saved Number redial)

Sched 4 105

Sched 5 105

Sched 6 105

scheduled services 102

security
 recommendations 111
 system 110

Select a line 40, 53

Select line out 68

Select line(s) 68

Send message? 40

Service Modes (see Services)

Service Modes ON 104

Service provider features
 Automatic Call Back 113
 Automatic Recall 114
 Call Forward 113
 calling the number your calls are forwarded to 113
 canceling Call Forward 113

Service Schedules
 Evening Sched 105
 Lunch Sched 105
 Night Sched 105
 Sched 4 105
 Sched 5 105
 Sched 6 105

Services
 overriding 104
 Restriction service 102
 Ringling service 102
 Routing service 102
 Trunk Answer 36
 turning off and on using feature codes 103
 viewing active schedules 103

set lock 107

Set locked 137

SHOW 26

signal
 Link 108
 Long Tones 108
 Pause 108
 run/stop 109
 Wait for Dial Tone 109

softkey display prompts, troubleshooting 121

special telephones 105

Speed Dial
 making a call 51
 programming for User 52

splitting a Conference Call 47

standard dial 42

Start of list 75

Still in transfer 58

stopping calls from ringing at your telephone 96

stuttered dial tone 112

suspending a call (see also Call Park and Hold)

switching between calls 123

system
 programming 19

system dial tone 112

System Speed Dial 51

T

T7100 telephone
 Autodial 49
 button defaults 90
 Button Inquiry 84
 Call Conference 45
 Call Park 60
 Call Queuing 138
 Call Transfer 57
 CallBack 59
 Conference Call 46
 Conference Call on hold 46
 extension numbers 23
 Hold 55
 line assignment 24
 Line button 42
 line button 30
 Line Redirection 65
 memory buttons 27
 one-line display 26
 Ring Again 138, 139
 Speed Dial 52
 standard dial 42
 Transferring a call 57
 Voice Call 75

T7208 telephone
 memory buttons 27

T7310 telephone
 Conference Call 46

T7316 telephone
 button defaults 88

- memory buttons 27
 - splitting a Conference Call 47
 - troubleshooting 125
 - two-line display 26
 - target lines 24
 - changing the name 23
 - telephone
 - alarm 125
 - Call Display information 32
 - CAP 33, 105
 - changing the name 23
 - control 103, 107
 - direct dial 105
 - extra dial 103, 105, 106
 - Hotline 106
 - log calls automatically 77
 - models 20
 - moving 95
 - prime 105
 - prime telephone 32
 - testing 125–127
 - testing
 - buttons 126, 127
 - ending a session 125
 - handset 126
 - headset 126
 - power supply 127
 - telephone 125
 - telephone speaker 126
 - text conventions 15
 - 3 Parties only** 47
 - time and date
 - displayed instead of messages and calls 91
 - displaying 99
 - 74
 - length of a call 99
 - time savers
 - autodial 49
 - Saved Number Redial 53
 - Speed Dial 51
 - tone
 - camped call tones 58
 - controlling length 108
 - remote access tones 112
 - voice call 75
 - tracking incoming calls
 - Call Log 77
 - transfer (see Call Transfer) 56–??
 - Transfer denied** 58
 - transferring calls 56
 - Callback 61
 - parking a call 60
 - using Camp-on 58
 - troubleshooting
 - decrease in voice quality 121
 - lost calls 122
 - reporting and recording alarms 125
 - softkey display prompts 121
 - testing
 - the headset 126
 - the power supply 127
 - the speaker in the handset 126
 - the telephone buttons 126
 - the telephone display 125
 - the telephone speaker 126
 - using the alarm telephone 125
 - Trunk Answer 36
- ## U
- Unequipped line** 68
 - Unknown name 80
 - Unknown number 53
 - until * 104
 - Use line pool?** 139
 - User Speed Dial 51
 - using Call Forward 63
 - using Do Not Disturb 96
 - using your system remotely 110–112
- ## V
- VIEW** 26
 - viewing
 - active Services 103
 - Call Log 78
 - messages 72, 74
 - Voice Call 75–76
 - Voice call** 76
 - voice mail
 - accessing your Business Communications Manager Voice Messaging system 112
 - using Call Forward 65
 - voice quality 121
- ## W
- Wait for Dial Tone 109
 - wireless Call Forward No Answer 123
 - wireless Portable Language Selection 123

Y

Your list full 75